

RANGEHOOD

900mm

RS9W (white fascia panel)

- White front fascia panel with white end caps
- 440m³/hr
- Twin motor
- Ducted operation
- Re-circulating operation (through cupboard only)
- 3 speed fan, controlled by slide switches
- Aluminium grease filters washable
- 2 x 40 watt halogen lamps

features



specifications

Airflow:	440m ³ /hr	Carbon Filter: CF110
Noise level:	56 dBA on maximum setting	
Lighting:	2 x 40 watt halogen	
Motor wattage	120 watt	
Power:	240 volt / 50Hz (fitted with 10amp, 3 pin plug)	
Power Cord:	1.5 metre cable	
Ducting Spigot size:	120mm	

dimensions

Product Dimensions 900mm (W) x 175mm (H) x 280mm* (D) (*not including 25mm front fascia panel)

Cut Out Dimensions 851mm (W) x 135mm (H) x 280mm[#] (D) ([#] cabinet only)

top vented recirculating through the top of the cabinet

CF110 Carbon Filter Code

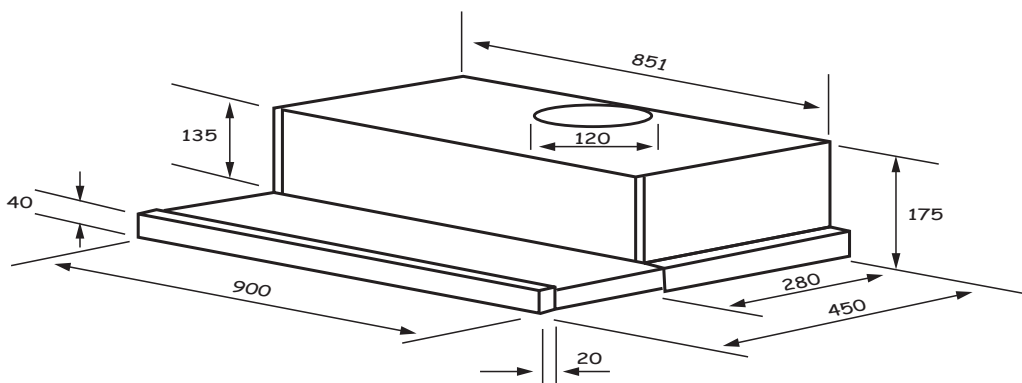

Warranty

2 years Parts and Labour
Customer Service

Our Nationwide Service Team can be contacted on our Toll Free Customer Service Number 1800 805 300 or by logging on to <http://customersupport.hapl.com.au/>