

# INTEGRATED RANGEHOOD

# 900mm

## IRI9WE3



- White - integrated into cupboard
- 1000m<sup>3</sup>/hr
- Ducted operation
- Re-circulating operation optional\*
- Back lit electronic push button
- 3 speed fan
- 2 x aluminium grease filters
- 2 x halogen lights

features

## specifications

<b>Airflow:</b>	1000m <sup>3</sup> /hr
<b>Noise level:</b>	65 dBA on maximum setting
<b>Lighting:</b>	2 x 20 watt halogen lights
<b>Total wattage</b>	305 watts
<b>Power:</b>	220 -240 volt / 50Hz (fitted with 10amp, 3 pin plug)
<b>Power Cord:</b>	1.5 metre cable
<b>Ducting Spigot size:</b>	150mm, 1.5m flexible duct piece supplied
<b>Carbon Filters:</b>	Optional CF260*, one required. Re-circulating through cupboard only
<b>Power:</b>	220-240V/50Hz

## dimensions

**Product Dimensions:** 865mm (W) x 360 mm (H) x 285mm (D)

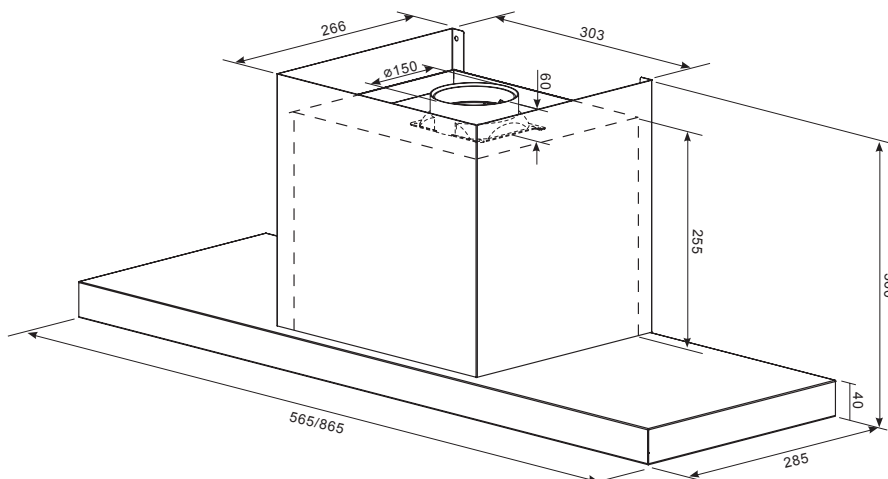

warranty - customer service

### Warranty

2 years Parts and Labour

### Customer Service

Our Nationwide Service Team can be contacted on our Toll Free Customer Service Number 1800 805 300 or by logging on to <http://customersupport.hapl.com.au/>

 **HOME APPLIANCES**

20 Carlotta Street  
Artarmon NSW 2064  
T: 02 9958 3111  
F: 02 9958 3555  
E: [info@hapl.com.au](mailto:info@hapl.com.au)

[www.hapl.com.au](http://www.hapl.com.au)