

# OVENS

900mm

## IOM9SE4



features

- 105L Net Capacity
- Sensor Touch
- 10 Multi functions
- Triple Glazed door
- 'Fast Cooking' Mode
- Catalytic Liners (Removeable)
- Memory function
- Child Safety Device
- Rotisserie
- Fully Programmable clock

### Dimensions

Product Dimensions: 482mm (H) x 897.5mm (W) x 564.5mm (D)\*

\* Includes 25mm front frame

### Important Installation Information

**NOTE:** Optimum ventilation will ensure cabinets and oven components to remain cooler and prevent possible overheating of the oven.

Please note the recommended rear space (40mm) gap and (A), check out in the supporting shelf of the oven, in order to improve ventilation around the oven. Minimum check out dimension recommendation is 700mm wide x 300mm deep.

### Specifications

|               |                    |
|---------------|--------------------|
| Power:        | 220 - 240V/50-60Hz |
| Lamps:        | 2 x 25W            |
| Output Power: | 3.17 - 3.66KW      |
| Direct Wired: | 15.25amps          |

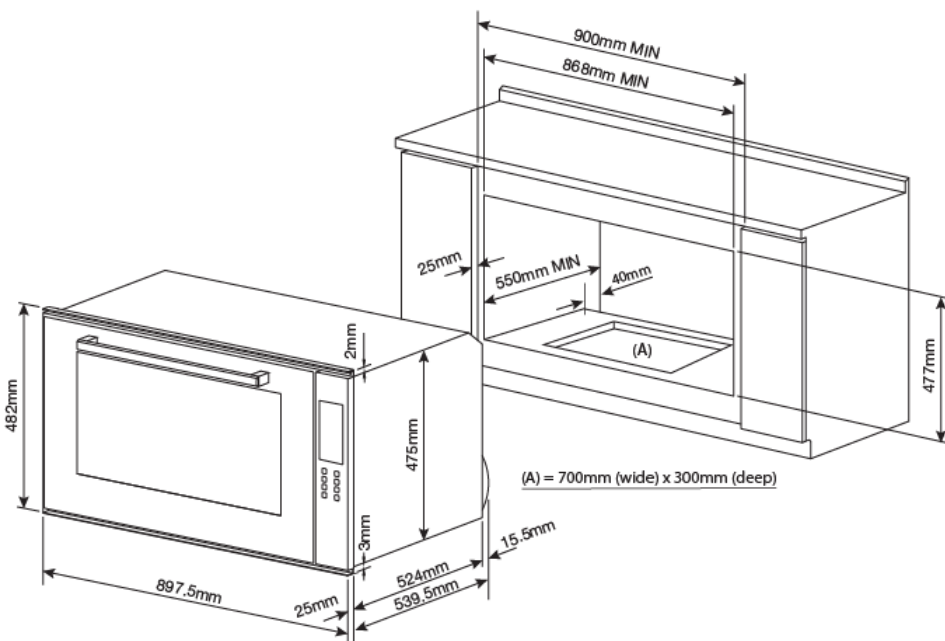

### Warranty

2 years Parts and Labour  
Customer Service

Our Nationwide Service Team can be contacted on our Toll Free Customer Service Number 1800 444 357 or by logging on to [customersupport.hapl.com.au/](http://customersupport.hapl.com.au/)

**HOME APPLIANCES**

20 Carlotta Street  
Artarmon NSW 2064  
T: 02 9958 3111  
F: 02 9958 3555  
E: info@hapl.com.au

[www.iagappliances.com.au](http://www.iagappliances.com.au)