

OVENS

900mm

IOC9SE3



- 110 Litres
- Easy to clean "acid resistant" enamel
- Double glazed door, removable inner glass for easy cleaning
- Fully programmable timer with digital clock display
- Removable door
- Storage area located under oven
- 5 shelf position
- Auto safety switch off
- Anti-tilt hook and safety chain (Must be fitted to wall to rear of cooker)

features

specifications

Functions:



Fan forced cooking



Conventional cooking



Fan assisted cooking



Bottom element with fan cooking



Fan assisted grilling



Grill heating element



Defrost



Oven light (stays on for all functions)

Total Load: 3.2kW (15amp connection)

Power: 220 – 240 volt/50Hz

dimensions

Product Dimensions: 875 – 930mm (H) x 900mm (W) x 600mm (D)

Cutout Dimensions: 910mm (H) X 910mm (W) X 600mm (D)

5mm space required either side of the appliance

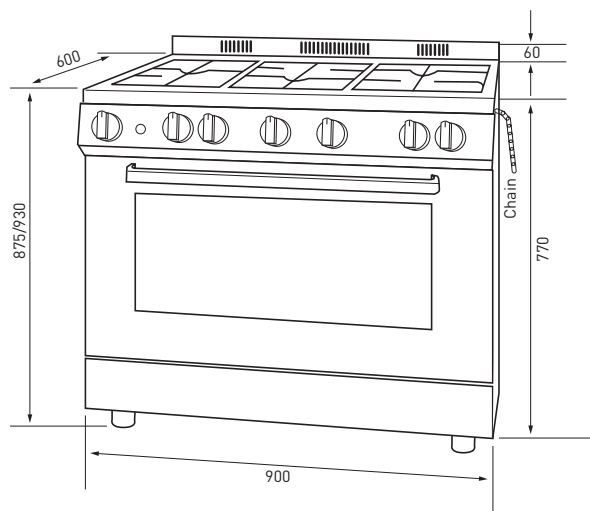

warranty - customer service

Warranty

2 years Parts and Labour

Customer Service

Our Nationwide Service Team can be contacted on our Toll Free Customer Service Number 1800 805 300 or by logging on to <http://customersupport.hapl.com.au/>

HOME APPLIANCES

20 Carlotta Street
Artarmon NSW 2064
T: 02 9958 3111
F: 02 9958 3555
E: info@hapl.com.au

www.hapl.com.au