

900mm Cooking Centre Manual

MODEL

IOC9SE3



Installation and Operation

The appliance was designed and made in accordance with the European standards listed below:
=> EN 30-1-1, EN 30-2-1 and EN 437 plus subsequent amendments (gas)
=> EN 60 335-1 and EN 60 335-2-6 (electrical) plus relative amendments

The appliance complies with the prescriptions of the European Directives as below:
=> 73/23 + 93/68 EC concerning electrical safety (BT).
=> 89/336 + 92/31 + 93/68 EC concerning electromagnetic compatibility (EMC)
=> 90/396 + 93/68 EC concerning gas safety.

Oven accessories that could come into contact with foodstuffs are made with materials that comply with the provisions of the 89/109 EC directive dated 21/12/88.

This product complies with EU Directive 2002/96/EC.
The crossed-out dustbin symbol reported on the appliance indicates that the appliance must be disposed of separately from other domestic refuse at the end of its useful life. It must therefore be delivered to a waste recycling centre specifically for electric and electronic equipment or returned to the retailer at the moment of purchase of a new equivalent appliance.



The user is responsible for delivering the appliance to the appropriate collection centre at the end of its useful life. Failure to do so may result in a fine, as provided for by laws governing waste disposal. Differential collection of waste products for eventual recycling, treatment and environmentally friendly disposal helps reduce possible negative effects on the environment and health, and also enables the materials making up the product to be recycled. For more detailed information on the available refuse collection systems, refer to the local Municipal Solid Waste disposal centre or the shop where the product was purchased. Producers and importers are responsible for fulfilling their obligations as regards recycling, treatment and environmentally friendly disposal by directly or indirectly participating in the collection system.

CONTENTS

ASSISTANCE AND SPARE PART	3
IMPORTANT NOTES AND PRECAUTIONS FOR USE	4
DESCRIPTION OF THE APPLIANCE	5-7
INSTRUCTIONS FOR THE USER	8-15
TROUBLESHOOTING	16
INSTRUCTIONS FOR THE INSTALLER	17-24
TECHNICAL FEATURES	25-26

ASSISTANCE AND SPARE PARTS

Before this appliance left the factory it was tested and set by specialized, expert personnel in order to guarantee the best functioning results.

Any subsequent repairs or adjustments that may be necessary must be done with the maximum of care and attention by authorised personnel.

For this reason we recommend you always contact us (refer below), specifying the brand, model, serial number and type of problem you are having with it. You will find the relative data printed on a label affixed on the appliance and on the label affixed to the packing box.

IMPORTANT NOTICE

The manufacturer shall not be held responsible for any damage to persons or property caused by incorrect installation or use of the appliance.

For prompt warranty service, please ensure that the warranty registration form is completed and return posted to us.

A duplicate data label and wiring diagram are contained in this booklet. Please attach these labels to an accessible surface near by the appliance for easy reference.

You can purchase original spare parts from authorised dealers or direct from us.

DOMESTIC USE ONLY

SPACE FOR DATA LABEL

IMPORTANT NOTES AND PRECAUTIONS FOR USE

You have purchased one of our products for which we thank you. We are confident that this new appliance, modern, functional and practical, made with top quality materials, will meet all your demands. This new appliance is easy to use but before installing and using it, **it is important to read this handbook through carefully**. It provides information for a safe installation, use and maintenance. Keep this handbook in a safe place for future reference.

The manufacturer reserves the right to make all the modifications to its products that it deems necessary or useful, also in your interests, without prejudicing its essential functional and safety characteristics. The manufacturer cannot be held responsible for any inaccuracies due to printing or transcription errors that may be found in this handbook.

N.B.: the pictures shown in the figures in this handbook are purely indicative.

- The installation, adjustments, conversions and maintenance operations listed in "section INSTRUCTIONS FOR THE INSTALLER" must only be carried out by authorised personnel.
- The installation of all-gas and combi appliances must comply with the standards in force.
- The appliance must only be used for its original purpose, that is, cooking for domestic use. Any other use is considered improper and, as such, dangerous.
- The manufacturer cannot be held responsible for any damage to persons or property resulting from an incorrect installation, maintenance or use of the appliance.
- Once the packaging has been removed from the outer surfaces and the various inner parts, thoroughly check that the appliance is in perfect condition. If you have any doubts do not use the appliance and call in an authorised person.
- The packaging materials used (cardboard, plastic bags, polystyrene foam, nails, etc.) must not be left with in easy reach of children because they are a potential hazard source. All packaging materials used are environmentally-friendly and recyclable.
- The electrical safety of this appliance is only guaranteed if it is correctly connected to a suitable earth system, as prescribed by the electrical safety standards. The manufacturer disclaims all responsibility if these instructions are not followed. Should you have any doubts, seek the assistance of an authorised person.
- Before connecting the appliance ensure that the rating plate data corresponds to that of the gas and electricity supply (see "section TECHNICAL FEATURES").

There are a few basic rules that must be observed when using the appliance:

- => Do not touch any electrical appliance if hands or feet are wet or damp.
 - => Do not use the appliance bare footed.
 - => Do not pull the power lead to take the plug out of the socket.
 - => Do not leave the appliance outside under the sun, rain, etc.
 - => Do not leave children or anybody who is incapable of correctly using the appliance unattended.
 - => Young children should be supervised to ensure that they not play with the appliance.
 - In order to prevent accidental tipping of the appliance, the stabilizing means must be installed. Please refer to instructions for installation.
 - Before cooking for the first time, ensure the oven is empty and its door closed, heat the oven at maximum temperature for two hours. This will allow the protective coating on the interior of the oven to be burnt off and dissipate the associated smells. Ensure adequate ventilation in the kitchen whilst burning off and don't be alarmed by a little bit of smoke during this process.
 - During cooking and for a while after use, the oven door glass and accessible parts can be very hot so keep children well away.
 - Keep the appliance clean. Food deposits could be a fire risk.
 - Avoid using the oven as a larder or as a saucepan cupboard when you are not using it for cooking: if the oven is turned on accidentally it could cause damage and accidents.
 - If you are using an electrical socket near the appliance, make sure that the cables are not touching the cooker and are far enough away from all hot parts.
 - When you have finished using the appliance check that all the controls are in the off or closed position, checking that the "0" of the knob corresponds to the "•" symbol serigraphed on the front panel.
 - Switch off the electrical supply before you start cleaning or servicing the appliance.
 - In the case of a failure or malfunction, turn the appliance off and switch off the electrical supply and do not tamper with it. All repairs or adjustments must be carried out with maximum care and the proper attention of an authorised person.
- For this reason we recommend you call our Service Centre.

DESCRIPTION OF THE APPLIANCE

PRESENTATION

Our cooker is fitted with a fully gas hotplate. This innovative burner hotplate offers you more scope and versatility in hotplate cooking than ever before. The round burners are graduated in their size and output to provide the exact heat required for every style of cooking. For example, the large or wok burner will give you the intense heat required for wok cookery, while the small simmer burner will handle the smallest of saucepans with ease and safety. The low heat (simmer) setting is extraordinarily low, so you can cook the most delicate sauces to perfection. This innovative, yet very practical combination of burners allows you to cook an entire meal on the hotplate at once and is of special assistance when entertaining. Each knob on the front panel has a diagram printed above it showing to which burner it refers.

The oven is fully electrical with electric grill. This can be either conventional or forced type (with fan).

The cooker has an accessory (e.g. electronic clock with end-of-cooking, a programmer,...) which makes it possible to use the oven without supervision. In order to guarantee the customer a good and safe use of the appliance, in addition, it has a safety thermostat that starts working in case of failure of the main thermostat. In such an event, the electricity is interrupted temporarily: **do not attempt to repair it yourself but turn the appliance off and contact your nearest Assistance Centre.**

The oven walls are fitted with various guide bars (fig. 1) on which the following accessories can be placed (fig. 2):

- **oven shelf rack (Gf).** Ensure shelf is located with dish and tray stop pointing upwards and at rear of oven.
- **food grill shelf (Gv)**
- **drip tray (V)**
- **handle (D)**

The cookers are equipped with a small compartment under the oven which can be used for the storage of items or to keep food warm when the oven is in use.

Do not use for storing inflammable materials.

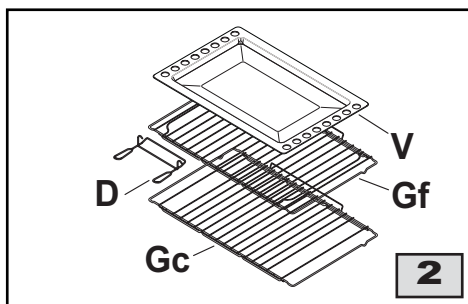
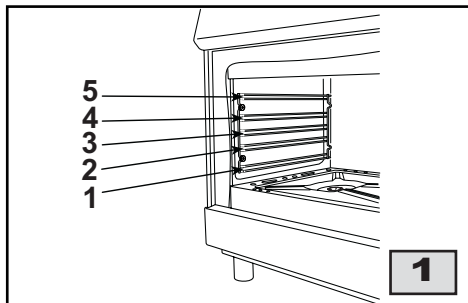

DESCRIPTION OF THE APPLIANCE

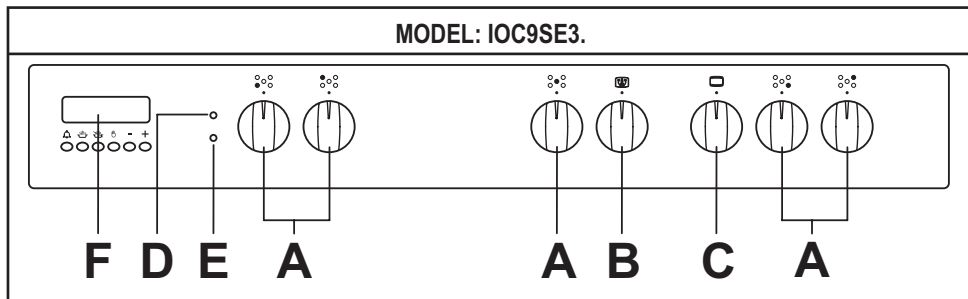



CONTROL PANEL

- A. Gas burner knob
- B. Oven thermostat knob
- C. Function selector knob
- D. Red warning light
- E. Yellow warning light indicating oven thermostat activation
- F. Electronic programmable clock

CONTROLS

HOB GAS BURNER KNOB (ref. A)

By rotating the knob in an anticlockwise direction, the following symbols appear:









- 0 = Closed position
-  = "Full on" position
-  = "Reduced rate or Low" position

OVEN THERMOSTAT KNOB (ref. B)

By turning the oven knob clockwise we will find the different oven temperature values (from 50°C to Maxi).

OVEN FUNCTION SELECTOR KNOB (8) (ref. C)

By turning the knob to the right or to the left we will find the following symbols:

- 0 = Oven off
-  = Oven light on, which stays on for all functions
-  = Defrost
-  = Top and bottom heating elements
-  = Top and bottom heating elements and fan
-  = Bottom heating element and fan
-  = Fan forced heating element and fan
-  = Grill heating element
-  = Grill heating element and fan

RED WARNING LIGHT (ref. D)

When lit it indicates that the electric grill or one of the oven electric components is on.

YELLOW WARNING LIGHT (ref. E)

If present, when lit it indicates that either the electric oven or electric grill is working. While the oven is being used the light will switch off when the set temperature is reached. During baking it is normal for the yellow light to switch on and off several times as the oven temperature is controlled.

DESCRIPTION OF THE APPLIANCE

ELECTRONIC PROGRAMMER (ref. F)

The programmer can select the following functions:

- Clock (set by keys 2 and 3)
- Minute counter (set by key 1)
- Cooking time (set by key 2)
- End of cooking (set by key 3)
- Manual operation mode (set by key 4)
- Setting time backwards (set by key 5)
- Setting time forward (set by key 6)

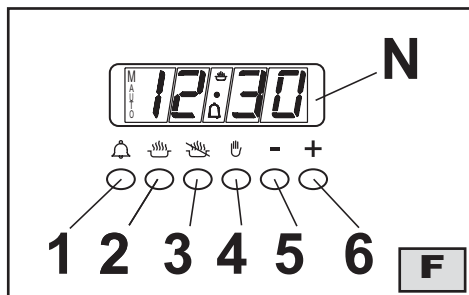

The digital display (N) always shows the time and can display cooking and end of cooking time or the minute counter time by pressing the corresponding push button.

N.B.: At the end of each setting session (except for the minute counter) the programmer turns the oven off. Check when next using the oven, if the programmer is not going to be used, that the latter is set on manual operation (see the instructions given further on).

Setting the time (from 0.01 to 24.00 = hh,mm)

After connecting to the electricity mains or subsequent to a power cut, AUTO and "0.00" will both flash simultaneously on the display.

Press push buttons 2 and 3 simultaneously and start setting the current time by pressing push button 5 or 6. Once set the AUTO symbol will turn off and the symbol, for manual operation, will turn on.

Minute counter (from 0.01 to 0.59 = hh,mm)

Press push button 1 and select cooking time with push button 5 or 6. The symbol turns on. At the end of the set time the buzzer will go off and the symbol turns off.

Semi-automatic operation

(with cooking time from 0.01 to 23.59 = hh,mm)

By pressing push button 2 and setting the length of cooking time with push button 5 or 6, the AUTO and symbols will light up and stay on all the time. At the end of the set time the symbol will turn off, the AUTO symbol will flash and the buzzer will go off.

Semi-automatic operation

(with end of cooking time from 0.01 to 23.59 = hh,mm)

By pressing push button 3 and setting the end of cooking time with push button 6, the AUTO and symbols will turn on and stay on all the time. At the end of the set time the symbol will turn off, the AUTO symbol will flash and the buzzer will go off.

Automatic operation

(with the start of cooking time delayed)

First programme cooking time (both the AUTO and symbol will turn on) and then the end of cooking time (the symbol will turn off) as described previously. The symbol will turn on again when baking in the oven starts. At the end of cooking time the symbol will turn off, the AUTO symbol will flash and the buzzer will go off.

Manual operation

Manual operation is only possible when the automatic programming has finished or after having cancelled it by pressing push button 4. The AUTO symbol disappears and the symbol turns on.

Buzzer

The buzzer will go off at the end of a programme or at the end of the minute counter function and lasts about 7 minutes. The buzzer can be stopped by pressing one of the function push buttons.

Programme start and control

The programme starts after setting. The programme set can be controlled at any time by pressing the corresponding push button.

Correcting/cancelling the programme setting

An automatic function programming error will occur if the time shown on the clock is between the cooking start time and cooking end time. This error will be signalled immediately by a buzzer and the AUTO symbol will flash. A setting error can be corrected by altering the duration or end of cooking time. Any programme that has been set can be corrected at any time by pressing the corresponding programming key and then key 5 or 6. To cancel a programme, correct the time set bringing it to a value of "0.00". If functioning time is cancelled the end of functioning is cancelled too and vice versa. The oven turns off automatically and the AUTO symbol flashes. Press key 4 to set the programmer on manual operation. The right time cannot be corrected when the automatic operation programme is working.

INSTRUCTIONS FOR THE USER

HOB: GENERAL NOTES ON SAFETY

- When using the burners, do not leave the appliance unsupervised. Ensure that children and the infirm do not play with the appliance. In particular, make sure that pan handles are positioned correctly and supervise the cooking of foods which use oils and fats, as these are highly inflammable.
- Do not use aerosols or sprays near the appliance when it is in use.
- Even after use, the burners remain hot for a long period; to avoid burning, do not place hands or other objects on them.
- After using the appliance, ensure that all the controls are in the closed or off position.

AUTOMATIC ELECTRIC IGNITION OF COOKTOP BURNERS

Push lightly the knob (ref. A) which corresponds to burner to be ignited and turn anti clockwise to the "Full On" position, then depress the control knob. Automatically the ignition spark shoots. If there is no electric power the burner may be lit with matches.

OPTIMUM USE OF COOKTOP BURNERS

In order to achieve maximum efficiency with minimum gas consumption it is useful to remember:

- Do not use large burners with pans of small diameter in order to avoid flames spreading wider than pans (consult the following table) and always use pans with lids (see fig. 3).
- When the boiling point is reached, it is best to turn the knob to the "Low position".
- Avoid using over sized pans that may radiate excessive heat and cause damage to surrounding surfaces such as bench tops and glass lid.
- The appliance is equipped with a particular pan support (1) on which must be put the wok support (2). To ensure stability, position the notch (A) of wok support on the pan support fingers as indicated in fig. 4 .
- Do not place anything, e.g. flame tamer, asbestos mat, between pan and pan support, as serious damage to the appliance may result (fig. 5).
- Locate pan centrally over the burner so that is stable and does not overhang the appliance (fig. 6).
- If gas burns with a yellow flame, do not continue to use burner and arrange for service.
- Do not use burners without the proper pan support or wok stand, as this will concentrate and deflect the heat onto the hotplate (fig. 7) and surrounding surfaces.

- Use only a wok support supplied or recommended by the manufacturer of the appliance (fig. 8).

ABNORMAL OPERATION

Any of the following are considered to be abnormal operation and may require servicing:

- Yellow tipping of the hob burner flame.
- Sooting up of cooking utensils.
- Burners not igniting properly.
- Burners failing to remain alight.
- Burners extinguished by the oven door.
- Gas valves, which are difficult to turn.

In case the appliance fails to operate correctly, contact our Service Centre.

Warning: Servicing should be carried out only by authorised personnel.

Burners	Ø pan cm
Wok	22÷24
Large	20÷22
Medium	16÷18
Small	12÷14

INSTRUCTIONS FOR THE USER

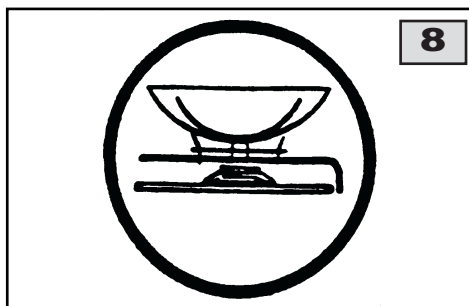
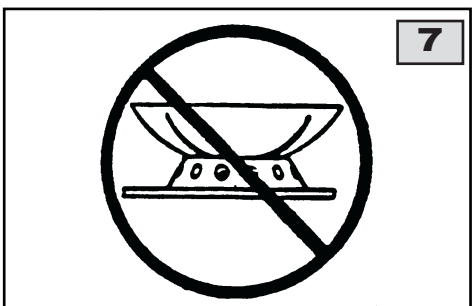
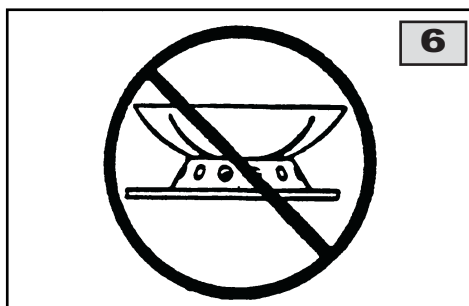
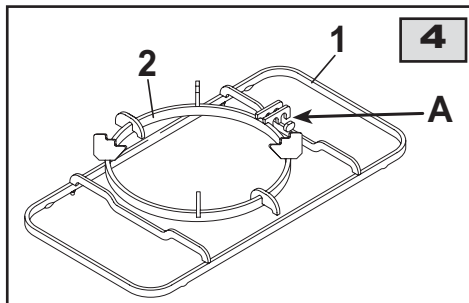
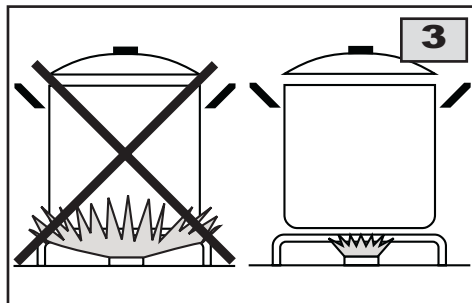

INSTRUCTIONS FOR THE USER

OVEN: GENERAL SAFETY INSTRUCTIONS

- Do not leave the oven unsupervised during use. Ensure that children and the infirm do not play with the appliance.
- Do not spray aerosols in the vicinity of this appliance while it is operating.
- Where this appliance is installed in marine craft or in caravans, it shall not be USED AS A SPACE HEATER.
- Always grip the centre of the oven door when opening. Do not practice excessive pressures on the door when it is open.
- Do not worry if condensation forms on the door and on the internal walls of the oven during cooking. This does not compromise its efficiency.
- When opening the oven door, be very careful of scalding vapours.
- During use the appliance becomes hot. Care should be taken to avoid touching heating elements inside the oven. Wear oven gloves when placing or removing pans from the oven or use, if equipped, the handle (D) (fig. 2) provided. Hook the handle to the edge of the tray and pull it out, slightly lifting it as you do so.
- When inserting or removing food from the oven, check that excess juices do not overflow onto the oven base (oils and fats are highly inflammable when overheated).
- Use containers that will resist the temperatures indicated on the thermostat knob.
- Never cover the base of the oven or the oven shelf with aluminium foil or other materials, as this creates a fire hazard.
- When grilling always put a little water in the grill pan. The water prevents the grease from burning and from giving off bad smells and smoke. Add more water during grilling to compensate for evaporation.
- After using the appliance ensure that all the controls are in the off position.
- WARNING!!! During and after use, the oven door glass and the accessible parts can be very hot, therefore keep children away from the appliance.

WHAT TO DO THE FIRST TIME YOU USE THE OVEN

- Remove all protective wrapping materials from the appliance and labels from the oven door.
- Remove combustible materials from the warming compartment before commissioning the cooker.
- Before cooking for the first time, **place the programming accessory, on the manual position** and, heat the oven at maximum temperature for 2 hours. This will allow the protective coating on the interior of the oven to be burnt off and expel the associated smells. Ensure adequate ventilation in the kitchen whilst burning off and don't be alarmed by a little bit of smoke during this process. At the end of this time period, allow the appliance to cool down and then clean the interior using hot water and a delicate detergent. Also wash all the accessories (grills, trays, spit roast, etc.) before use.

Prior to any cleaning, disconnect the appliance from the electricity mains.

For your information you will find a brief description of different cooking methods:

- on page 11, how to use electric multifunction oven and electric grill to forced convection
- on page 12, some useful cooking tips to get the best results
- on page 13, you will find the tables for cooking and grilling.

IMPORTANT!! Always keep the oven door closed during baking or grilling.

INSTRUCTIONS FOR THE USER

HOW TO USE THE MULTIFUNCTION OVEN



DEFROSTING AT ROOM TEMPERATURE

Turn the selector knob (ref. C) to the symbol and place the food you want to defrost inside the oven.

The length of time required depends on the quantity and type of food.

Selecting this function will only activate the fan. Mild air circulation around frozen food will slowly defrost it. It is particularly suitable for fruit and cakes.



TRADITIONAL COOKING

Turn the selector knob (ref. C) to the symbol and adjust the thermostat knob (ref. B) to the desired temperature.

If pre-heating is recommended wait till the thermostat yellow warning light (ref. D) turns off before placing foods inside the oven. This option turns on both bottom and top heating units, evenly distributing heat on your foods.

This type of cooking is ideal for all kind of foods (meats, fish, bread, pizzas, cakes..).



COMBINED TRADITIONAL + FAN COOKING

Turn the selector knob (ref. C) to the symbol and adjust the thermostat knob (ref. B) to the desired temperature.

If pre-heating is recommended wait till the thermostat yellow warning light (ref. D) turns off before placing foods inside the oven. This option turns on both bottom and top heating units, and heat is distributed by fan ventilation.

This combination is suitable for rapid cooking and allows for the use of more plates positioned on the different levels of the oven.



DEFROSTING + WARM UP BY HOT AIR

Turn the selector knob (ref. C) to the symbol and adjust the thermostat knob (ref. B) to the desired temperature, then place the food inside the oven.

Selecting this function will activate the bottom heating unit and its heat is distributed by the fan. This function is particularly recommended to defrost and warm up ready-made meals.



FAN FORCED COOKING

Turn the selector knob (ref. C) to the symbol and adjust the thermostat knob (ref. B) to the desired temperature, then place your food inside the oven.

If pre-heating is recommended wait till the thermostat yellow warning light (ref. D) turns off before placing foods inside oven. This function activates the rear heating unit and the fan distributes the heat produced. This combination allows for a fast and even cooking of several different foods placed on the diverse levels of the oven.



CONVENTIONAL GRILL COOKING

Turn the selector knob (ref. C) to the symbol and adjust the thermostat knob (ref. B) to the desired temperature. Selecting this function the top central heating element turns on and heat is distributed directly on food surface.

Apart from grilling, this function is ideal to add a golden roast to your recipes or to toast bread slices.

The grill function automatically activates the spit.

When you use the grill, do not forget to place the drip pan beneath it to collect any sauce dripping, as suggested in the "USEFUL COOKING TIPS " section.



FAN GRILL COOKING

Turn the selector knob (ref. C) to the symbol and adjust the thermostat knob (ref. B) to the desired temperature (MAX 200°C). Selecting this function the top central heating element turns on and heat is distributed by the fan. This procedure mitigates the direct heat on food surface and uses milder temperatures. It is therefore recommended for an even golden and crispy finish touch, ideal for whole fish and poultry.

When you use the grill, do not forget to place the drip pan beneath it to collect any sauce dripping, as suggested in the "USEFUL COOKING TIPS " section.

INSTRUCTIONS FOR THE USER

USEFUL COOKING TIPS

Cakes and bread:

- Heat the oven for at least 15 minutes before you start cooking bread or cakes.
- Do not open the door during baking because the cold air would stop the yeast from rising.
- When the cake is cooked turn the oven off and leave it in for about 10 minutes.
- Do not use the enamelled oven tray or drip pan, supplied with the oven, to cook cakes in.
- How do you know when the cake is cooked? About 5 minutes before the end of cooking time, put a cake tester or skewer in the highest part of the cake. If it comes out clean the cake is cooked.
- And if the cake sinks? The next time use less liquids or lower the temperature 10°C.
- If the cake is too dry: Make some tiny holes with a toothpick and pour some drops of fruit juice or spirits on it. The next time, increase the temperature 10°C and set a shorter cooking time.
- If the cake is too dark on top: the next time put the cake on a lower shelf, cook it at a lower temperature and longer.
- If the top of the cake is burnt: cut off the burnt layer and cover with sugar or decorate it with cream, jam, confectioner's cream, etc..
- If the cake is too dark underneath: the next time place it on a higher shelf and cook it at a lower temperature.
- If the cake or bread is cooked nicely outside but is still uncooked inside: the next time use less liquids, cook at a lower temperature and longer.
- If the cake will not come out of the tin: slide a knife around the edges, place a damp cloth over the cake and turn the tin upside down. The next time grease the tin well and sprinkle it with flour or bread crumbs.
- If the biscuits will not come away from the baking tray: put the tray back in the oven for a while and lift the biscuits up before they cool. The next time use a sheet of baking parchment to prevent this happening again.

Meat:

- If, when cooking meat, the time needed is more than 40 minutes, turn the oven off 10 minutes before the end of cooking time to exploit the residual heat (energy saving).
- Your roast will be juicier if cooked in a closed pan; it will be crispier if cooked without a lid.
- Normally white meat, poultry and fish need medium temperatures (less than 200°C).
- To cook "rare" red meats, high temperatures (over 200°C) and short cooking times are needed.
- For a tasty roast, lard and spice the meat.
- If your roast is tough: the next time leave the meat to ripen longer.
- If your roast is too dark on top or underneath: the next time put it on a higher or lower shelf, lower the temperature and cook longer.
- Your roast is underdone? Cut it in slices, arrange the slices on a baking tray with the gravy and finish cooking it.

Grilling:

- Sparingly grease and flavour the food before grilling it.
- Always use the grill pan to catch the juices that drip from the meat during grilling.
- Always put a little water in the drip pan. The water prevents the grease from burning and from giving off bad smells and smoke. Add more water during cooking because it evaporates.
- Turn the food half way through cooking.
- If you are grilling fatty poultry (goose) pierce the skin under the wings after about half an hour so the fat can drip away.

The aluminium can be easily corroded if it comes into contact with organic acids present in the foods or added during baking (vinegar, lemon juice). Therefore it is advised not to put directly the foods on aluminium or enamelled trays, but ALWAYS use the proper oven paper.

INSTRUCTIONS FOR THE USER

COOKING / BAKING TIMETABLE

FOODS	Weight kg	Position of the oven shelf from the bottom	COOKING BY NATURAL CONVECTION		COOKING BY FORCED CONVECTION (WITH FAN)	
			Temperature in °C	Cooking Time in minutes	Temperature in °C	Cooking Time in minutes
MEAT						
Roast veal	1	1-2	200-225	100-120	190	100-120
Roast beef	1	1-2	200-225	40-50	190	40-50
Roast pork	1	1-2	200-225	100-120	190	100-120
Roast lamb	1	1-2	200-225	100-120	190	100-120
GAME						
Roast hare	1	1-2	200-Maxi	50-60	200-Maxi	50
Roast pheasant	1	1-2	200-Maxi	60-70	200-Maxi	60
Roast partridge	1	1-2	200-Maxi	50-60	200-Maxi	50
POULTRY						
Roast chicken	1	1-2	200-225	80-90	190	70-80
Roast turkey	1	1-2	200-225	100-120	190	90-110
Roast duck	1	1-2	200-225	90-110	190	80-100
FISH						
Roast fish	1	2-3	200	30-35	170-190	25-30
Casserole fish	1	2-3	175	20-25	160-170	15-20
BAKED PASTA						
Lasagne	2.5	3	210-225	60-75	225-Maxi	30-40
Cannelloni	2.5	3	210-225	60-75	225-Maxi	30-40
PIZZA	1	3	225-Maxi	25-30	225-Maxi	20-25
BREAD	1	3	225-Maxi	20-25	220	20
PASTRIES						
Biscuits in general		2	190	15	170-190	15
Shortcrust pastry		2	200	20	190-200	20
Victoria sponge	0.8	2	200	40-45	190-200	40-45
CAKES						
Angel cake	0.8	2	190	52	170-190	45
Fruit cake	0.8	2	200	65	190-200	65
Chocolate cake	0.8	2	200	45	190-200	45

The values given in the tables (temperatures and cooking times) are approximate and may vary according to each person's cooking habits. This table gives cooking times on only one shelf. If you are cooking with a fan oven and you are using more than one shelf (placing the shelves on the 2nd and 4th position or on the 1st and 3rd position) cooking time will be about 5 to 10 minutes longer.

GRILLING TIMETABLE

FOODS	Weight kg	Position of the oven shelf from the bottom	COOKING BY NATURAL CONVECTION			COOKING BY FORCED CONVECTION (WITH FAN)		
			Temperature in °C	Cooking Time in minutes		Temperature in °C	Cooking Time in minutes	
				1 st side	2 nd side		1 st side	2 nd side
MEAT								
Chop	0,50	3	225-Max	12-15	12-15	200	15	10
Beefsteaks	0,15	3-4	200-225	5	5	=	=	=
Half chicken (each half 0.500 Kg)	1	3-4	225	20	20	=	=	=
FISH								
Trout	0,42	4	225-Maxi	=	=	200	10	10
Sole	0,20	4	225-Maxi	=	=	200	7	7
BREAD								
Toast		4-5	225-Maxi	2-3	2-3	200	2-3	2-3

The values given in the tables (temperatures and cooking times) are approximate and may vary according to each person's cooking habits. In particular, temperatures and times for grilling meat will greatly depend on the thickness of the meat and on personal tastes.

INSTRUCTIONS FOR THE USER

CLEANING AND MAINTENANCE

Before cleaning or maintenance, isolate the cooker from the electricity supply. Never use a steam cleaner or caustic cleaner to clean this appliance, both to interior that to exterior. Failure to adhere, will avoid all warranties.

HOT PLATE

The pan supports and burner caps are enamelled and can be wiped over with warm soapy water. The alloy burners can also be cleaned in this way. Any obstinate marks can be removed using a paste or cream cleaner or a well moistened soap impregnated steel wool pad rubbed gently so as not to damage the surface. After cleaning, ensure that all the parts are dried and correctly replaced.

WARNINGS:

- Check that the heads burners and the relative burner caps, are correctly positioned in their housings (fig. 9).
- Take care not to disturb the ignition spark plugs or flame failure devices.
- If you find a tap is difficult to open or close do not force it but call for technical assistance urgently.

STRUCTURE

All the cooker parts (in enamelled or painted metal, steel, or glass) should be cleaned frequently with warm soapy water and then rinsed and dried with a soft cloth. DO NOT wash the parts if they are still hot. NEVER use sponges or abrasive products, and aromatic or aliphatic solvents to remove stains or adhesives on the painted or stainless steel surfaces. DO NOT leave vinegar, coffee, milk, salty water or the juice of lemon or tomato on the surface for any length of time.

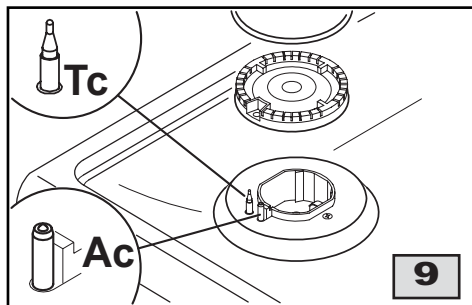

OVEN CAVITY

Do not spray or wash the thermostat bulb with acid based products (check the product label before use). The manufacturer cannot be held liable for any damage caused by incorrect cleaning.

The oven cavity should be cleaned after each use to remove cooking residuals and or grease or sugar which, if burnt on when the oven is used again, will form deposits or unremovable stains as well as unpleasant smells. The oven MUST always be cleaned whilst it is warm with warm soapy water.

To maintain the shine of the enamelled parts, clean them with warm soapy water, rinse and dry them thoroughly. DO NOT wash these parts if they are still hot and NEVER use abrasive powder cleaners and pads. DO NOT leave vinegar, coffee, milk, salty water or the juice of lemon or tomato on enamelled surfaces for any length of time. ALWAYS wash the accessories used.

OVEN SEAL

The oven seal guarantees the correct functioning of the oven. We recommend you:

- clean it, avoiding abrasive tools or products.
- check its state now and then.

If the oven door seal has become hard or is damaged, contact our Service Centre and avoid using the oven until it has been repaired.

REPLACING THE OVEN LAMP (fig. 10)

Ensure the appliance is switched off before replacing the lamp to avoid the possibility of electric shock..

In the event oven lamp need replacing, the new lamp must comply with the nominal data indicated on page 25 and must be resistant to high temperature (300°C). Turn glass protection cap (C) counterclockwise and change the lamp. Re-fit the cap, screwing it back in a clockwise direction.

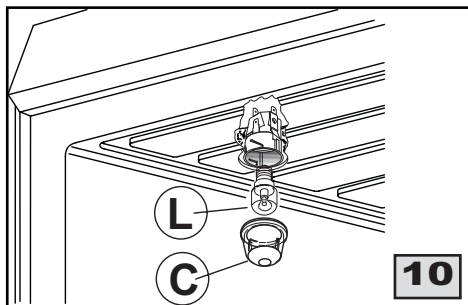

INSTRUCTIONS FOR THE USER

OVEN DOOR REMOVAL

The oven door can be removed to give easier access to the oven when cleaning. To remove, proceed as follows:

- Open the oven door and move the release U-shape element (fig. A) forwards until it is over the tooth in the sector of the hinge (fig. B).
- Partly close the door forcing it up at the same time to release it from lower stop tooth (fig. C) and then pull the door forwards tilting it slightly upwards to free upper hinge sector (fig. D).
- To reassemble proceed in reverse order, having care to introduce in their housings, first the superior sectors then the inferior sectors.

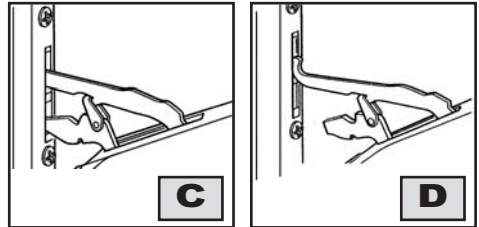
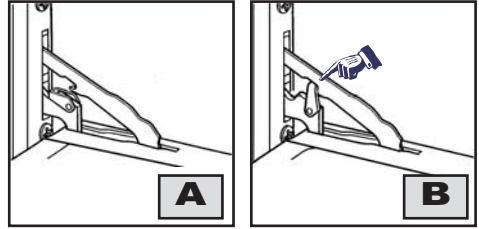

ATTENTION!!

Whenever you clean the oven, before you close the door, make sure that the release U-shaped elements are **TOTALLY LOWERED** as indicated in figure A.

DISASSEMBLY OF THE INNER OVEN DOOR GLASS

One of the features of our cookers is that the inner oven door glass can be easily removed for cleaning without the aid of specialized personnel. Just open the oven door and remove the support to which the glass has fixed (vedi fig. E).



ATTENTION!!

This operation can be done also with the door fitted on cooker, but in this way, pay attention that when the glass is pull upwards, the force of the hinges close the door roughly.

TROUBLESHOOTING

Some problems can be caused either as the results of simple maintenance operations or by incorrect selection of settings. Prior to contacting a Service Centre please check the following chart.

PROBLEM	REMEDY
The appliance is not working	<ul style="list-style-type: none"> Make sure the gas cock is open Check the plug is in Check that the knobs are set correctly for cooking and then repeat the operations given in the handbook Check the electrical system safety switches (RCD). If there is failure in the system call an electrician in.
The electric oven is not working	<ul style="list-style-type: none"> Check that the programmer accessory, if there is one, is on the manual position and then repeat the operations described in the manual
The thermostat is not working	<ul style="list-style-type: none"> Contact Service Centre..
The electric thermostat warning light does not switch on during use	<ul style="list-style-type: none"> Turn the thermostat round to a hotter temperature Turn the selector round to a different function
The oven light does not switch on	<ul style="list-style-type: none"> Make sure the lamp is firmly screwed in place Buy a lamp for high temperatures at one of our Service Centre and fit it following the instructions given on page 14.

Any of the following are considered to be abnormal operation and may require servicing:

- Yellow tipping of the hob burner flame.
- Sooting up of cooking utensils.
- Burners not igniting properly.
- Burners failing to remain alight.
- Burners extinguished by cupboard doors.
- Gas valves, which are difficult to turn.

In case the appliance fails to operate correctly, contact our Service Centre.

Warning: Servicing should be carried out only by authorised personnel.

6. INSTRUCTIONS FOR THE INSTALLER

TECHNICAL INFORMATION

The installations, conversions and maintenance operations listed in this part must only be carried out by authorised personnel. The manufacturer cannot be held responsible for any damage to persons or property resulting from an incorrect installation of the appliance.

- The safety and automatic adjustment devices of the appliances may, during its life, only be modified by the manufacturer or duly authorised supplier.
- This appliance shall be installed only by authorised personnel and in accordance with the manufacturer's installation instructions, local gas fitting regulations, municipal building codes, water supply regulations, electrical wiring regulations, AS 5601/AG 601 - Gas Installations and any other statutory regulations.
- Failure to install the appliance correctly could invalidate any manufacturer's warranty and lead to prosecution under the above quoted regulation.
- Before installation, make sure that local distribution conditions (gas and electrical) are compatible with the appliance's adjustment. Refer to data label for gas type.
- As it is not connected to a device for the evacuation of the products of combustion, it must be installed in accordance with current regulations and used in a well ventilated location. Particular attention must be paid to the regulations on ventilation.

VENTILATION

All rooms require an openable window or equivalent, while some rooms require a permanent vent in addition to the openable window.

Ventilation must be in accordance with AS5601/AG 601 - Gas Installations. In general, the appliance should have adequate ventilation for complete combustion of gas, proper flueing and to maintain temperature of immediate surroundings within safe limits.

The use of a gas appliance results in production of heat and moisture in the room in which it is installed. Ensure that the kitchen is well ventilated; keep natural ventilation holes open or install a mechanical ventilation device (mechanical extraction hood).

Prolonged intensive use of the appliance may call for additional ventilation, for example increasing the level of mechanical ventilation where present.

UNPACKING YOUR COOKER

- Once the packaging has been removed, thoroughly check that the appliance is in perfect condition. If you have any doubts do not use the appliance and call our Service Centre.
- Do not move the appliance by the handles.
- Some parts mounted on the appliance are protected by a plastic film. This protection must be removed before using the appliance. We recommend slitting the plastic film along the edges with a sharp knife or pin.

The packaging materials used (cardboard, plastic bags, polystyrene foam, nails etc.) must not be left anywhere within easy reach of children as they are a potential hazard source.

6. INSTRUCTIONS FOR THE INSTALLER

POSITION (fig. 11)

The appliance should be positioned in good light and free from draughts. Any adjoining wall surface situated within 200 mm from the edge of any hob burner must be a suitable non-combustible material for a height of 150 mm for the entire length of the hob. Any combustible construction above the hotplate must be at least 750 mm above the top of the burner and no construction shall be within 450 mm above the top of the burner.

Where a combustible surface adjacent to the cooker is less than 200 mm from the nearest burner it may be protected by a non-combustible protective layer in accordance with AS5601/AG601. The protection must ensure the surface temperature of the combustible surface does not exceed 65° C above ambient.

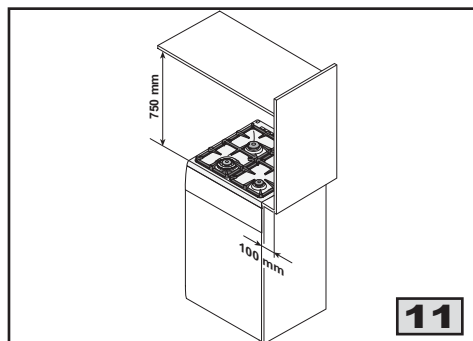

11

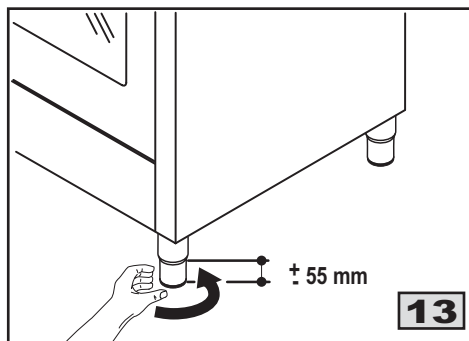

13

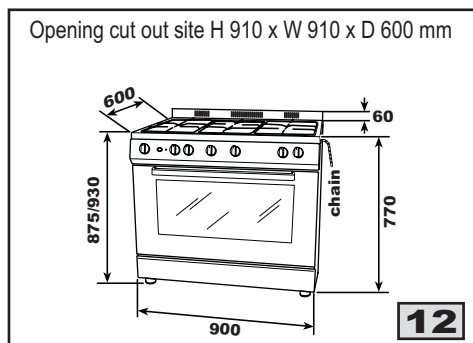

12

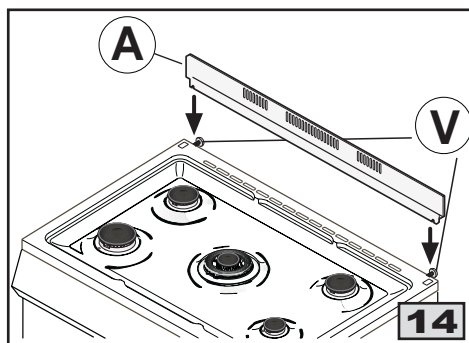

14

LEVELLING THE COOKER

- **Adjustable feet**, to be fitted to the appliance, which allow the height of the cooker to be aligned with other kitchen furniture. This can be done by means of the terminal part of the leg themselves (fig. 13)
- **Spacers**, positioned behind the rear panel to keep the appliance at the minimum required distance from the back wall. **These must not be removed.**
- **Backguard**. The cookers which are equipped with this accessory, leave of the factory with this particular inserted inside the packaging. In order to install the backguard, it is necessary to loosen the screws positioned on the back of the hob and then to fix the backguard as indicated in figure 14

6. INSTRUCTIONS FOR THE INSTALLER

SECURING THE COOKER TO WALL (fig. 15)

Note:- The installation of the chain provided is for safety reasons, it must be installed as indicated below.

To prevent the cooker tipping forwards in the event of children standing on the oven door or where users put extreme weight on the door when in open position, two lengths of chain **MUST BE** fixed to the back of the oven which should at all times be secured to the hooks provided. The hook should be secured to the wall at the back of the cooker. The chains should always be attached to the upper hooks when the cooker is in its position against the wall. Attach the chain to the lower hooks if the cooker is installed with a hose assembly so that there is no strain on the hose when the cooker is pulled forward for cleaning or maintenance.

WARNING: If the cooker is installed between two cupboards and the stabilising chains cannot be installed to stabilise the cooker, please contact our Service Centre.

Assembly instructions

- Fix hook into wall immediately behind and to the left-hand side about 770 mm from the floor.
- Secure the chain to the hook before using or cleaning etc. of the cooker (see figure 15).
- To prevent strain on the Flexible Hose assembly, a chain & hook is necessary approx. 100 mm up from the floor.

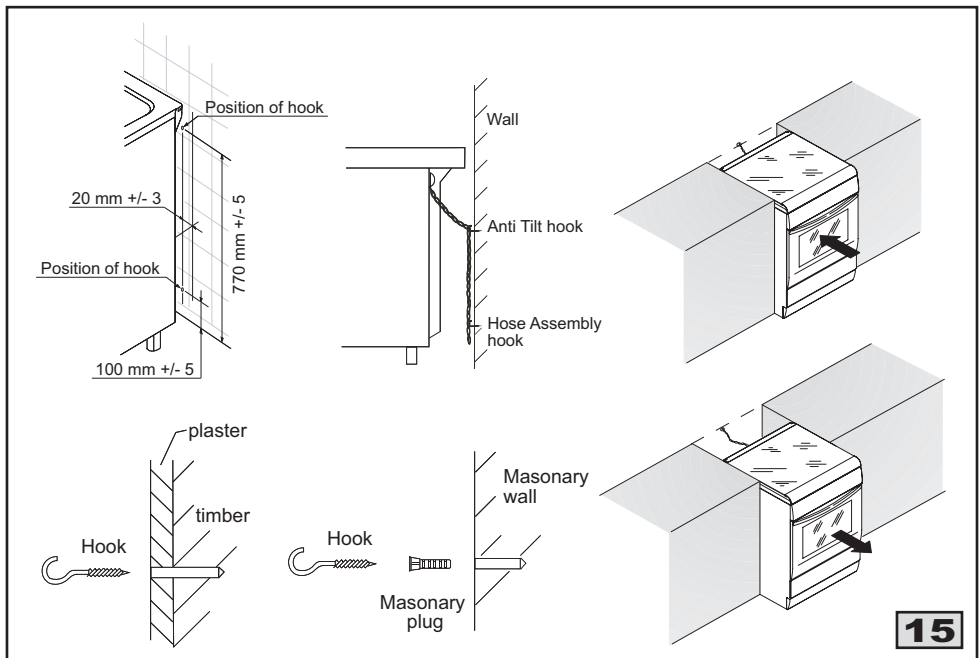

6. INSTRUCTIONS FOR THE INSTALLER

GAS CONNECTION

This appliance shall be installed only by authorised personnel and in accordance with the manufacturer's installation instructions, local gas fitting regulations, municipal building codes, water supply regulations, electrical wiring regulations, AS 5601/AG 601 - Gas Installations and any other statutory regulations.

The appliance is adjusted to work at gas indicated on the label which is applied on the glass-window of the oven door and on the cooker packing.

Installation for Natural gas

Connected regulator (B) to fitting (A) which is then fitted to elbow (F). Ensure arrow on regulator point in the direction shown. Fitting (D) to be supplied by installer (fig. 16). Adjust regulator to give test-point pressure given on data label and on page 25, with one large or one medium burner alight at maximum.

Position of Regulator

If stove is to be installed on legs, a gas pipe between fitting (A) and (B) (fig. 16) will allow location of the regulator (B) underneath the stove for adjustment and maintenance. If stove is installed on it's base, the regulator should be fitted at rear of stove on fitting (E) (fig. 16) for maintenance and adjustment.

Note: When the regulator is fitted at the rear of the cooker at least 60 mm clearance is required.

Installation to L. P. Gas

Connect by using a copper pipe starting, from the threaded fitting of elbow (F) (fig. 17).

When converting from Natural Gas to Propane ensure that the NG regulator is removed and replaced with the Test Point Assembly. A gas regulator suitable for a supply pressure of 2.75 kPa should be part of the gas tank supply.

Installation using flexible connection

As an option, the cooker may be installed with a flexible connection hose, which complies with AS/NZS 1869 (AGA Approved), 10mm ID, class B or D, Minimum 1000 mm - Maximum 1200 mm, as an alternative connection.

- The hose is connected to the appliance at the rear to the right hand corner and faces downwards.
- An isolating tap and pressure regulator must be fixed to the rear wall and the flexible pipe attached by means of a union connector.
- The gas connection and isolating tap must be accessible to a service person or inspector.
- The hose assembly must be installed in accordance with AS5601 for a high level connection. The hose should not be subjected to abrasion, kinking or permanent deformation and should be able to be inspected along its entire length. Unions compatible with the hose fittings must be used and connections tested for gas leaks. The fixed consumer piping outlet should be at approximately the same height as the cooker connection point, pointing downwards.
- The hose should be clear of the floor when the cooker is in the installed position. The anti-tilting chain supplied should be anchored to the lower hook fixed to the wall so that the chain prevents strain on the hose connections when the cooker is pulled forward.

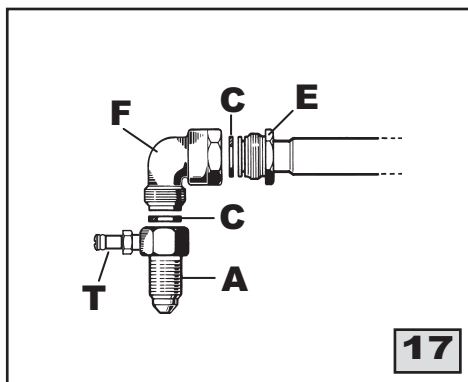
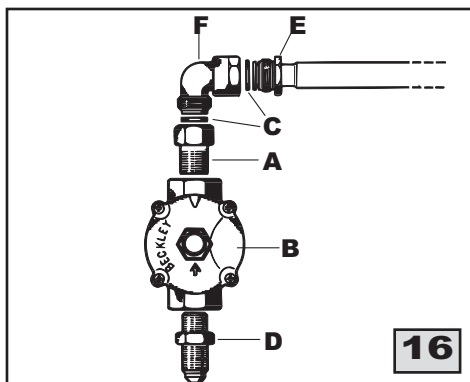

6. INSTRUCTIONS FOR THE INSTALLER

ELECTRICAL CONNECTION

The electrical connection must be carried out in accordance with the current standards and laws in force and by an authorised electrician.

- **Warning this appliance must be earthed.**
- Connection to the electricity supply must be made by an authorised electrician to a suitable isolating switch in accordance with the requirements of SAA Wiring Rules, AS/NZS 3000.
- A cable of the correct rating must be used (see Electrical components).
- Means of disconnection shall be provided in the fixed wiring in accordance with the Australian wiring rules.
- **Remember that the earth wire must be longer than the phase wires.**
- **Note:** The power supply cable must be positioned so that no part of cable can come into contact with any surface which could reach temperatures in excess of 75 K.

ADJUSTMENTS

- **Always disconnect the appliance from the electricity supply before making any adjustment.**
- **All seal must be replaced by the technician following any adjustment or regulation.**
- **The adjustment of the reduce rate (simmer) must be undertaken only with burners functioning on natural gas while in the case of burners functioning on L.P.G, the screw must be locked down fully (in clockwise direction).**
- **“Primary air adjustment” on hob gas burners is unnecessary.**

TAPS (see fig. 18)

All gas taps are male cone type with only one way of passage.

Adjustment of the **“Reduced rate”** position as follows:

- Turn the burner on and place the knob on the “Reduced rate” position (small flame).
- Remove the knob of the tap which is attached by simply applying pressure to the rod.
- Insert a small screwdriver (C) into the tap shaft and turn the throttling screw left or right until flame of the burner is conveniently regulated to the low position.
- Check that the flame does not go out when the knob is sharply switched from the “Full on” to “Reduced rate” positions.

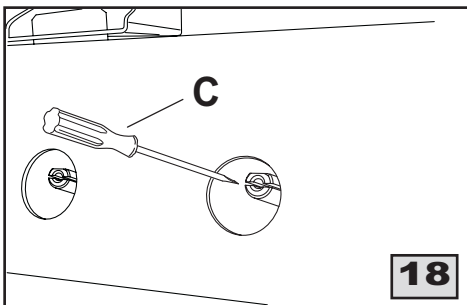

6. INSTRUCTIONS FOR THE INSTALLER

NOTE:

Hot Plate Ignition Failure

- Check alignment of burner holes to electrode.
- Check aeration sleeve for adjustment for gas type, location and ambient conditions.
- No spark, check ignition box failure or power supply.

Before Leaving

- Check all connections for gas leaks with soap and water. **DO NOT** use a naked flame for detecting leaks. Ignite all burners to ensure correct operation of gas valves, burners and ignition.
- Turn gas taps to low flame position and observe stability of the flame. When satisfied with the cooker, please instruct the user on the correct method of operation.
- In case the appliance fails to operate correctly after all checks have been carried out, refer to the authorised service provider in your area.

GAS CONVERSIONS

When converting from Natural Gas to Propane ensure that the NG regulator is removed and replaced with the Test Point Assembly. An AGA Approved gas regulator suitable for a supply pressure of 2.75kPa should be part of the gas tank supply and the test point pressure should be adjusted to 2.75kPa.

Replace the old data plate with one, which is suitable for the type of gas for which the appliance has been regulated.

REPLACING THE INJECTORS

Our burners can be adapted to different types of gas by simply installing the injectors suitable for the gas you want to use. To help the installer, the table on page 25 gives the burner nominal heat input, injector diameter and operating pressure of the different gas types.

Comply with the following instructions:

Injector replacement - Hob burners.

To change the injectors on the hob, remove the burner cup and head and with a 7 mm Ø socket spanner replace them (fig. 19).

After having replaced the injectors, it will be necessary to proceed with burner adjustment as explained in the previous paragraphs.

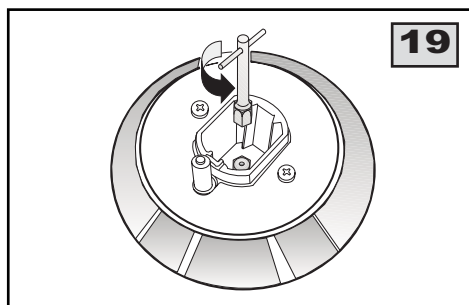

6. INSTRUCTIONS FOR THE INSTALLER

MAINTENANCE

Prior to any maintenance work or changing parts, disconnect the appliance from the gas and electricity power sources. Servicing must only be carried out by authorised personnel.

REPLACING THE TAPS

Proceed in the following way when replacing a tap:

- Remove pan supports, burner heads.
- Unscrew the burner fixing screws (Vc) (fig. 20). (four for ultrarapid burner and two for the other burners)
- Unscrew the two fixing screws (Vd) (fig. 20) which lock the hob at the back and remove it.
- Pull out the knobs.
- Unscrew the three fixing screws (Vf) (fig. 20) which lock the front panel to the front frame then slip out from the upper fixing brackets.
- Unscrew the nuts (D) of the gas aluminium pipes and pull out the thermocouple quick connectors (F) (fig. 22).
- Unscrew the screws (Vt) (fig. 21) which lock the crosspieces.
- Unscrew the screws (Vb) (fig. 21) which unite the the bridles of the taps to the front frame.
- Make to slip the ramp toward the back part and unscrew the screws (Vb) (fig. 22) in order to free the taps.
- Change seal each time a tap is replaced. This will ensure perfect retention between the tap and part.
- Reassemble all the parts following the same procedure but in the reverse order.

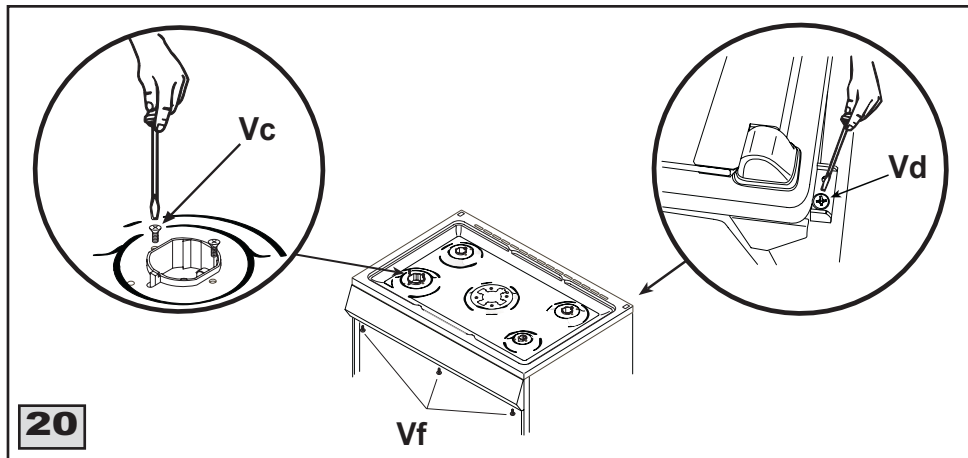
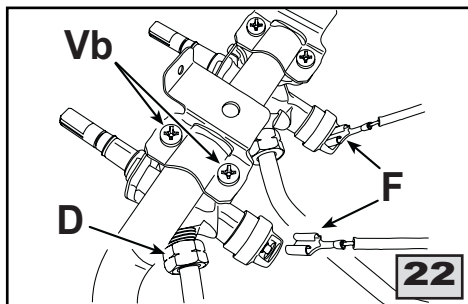
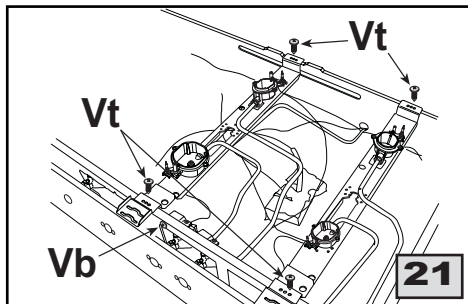

6. INSTRUCTIONS FOR THE INSTALLER

CHANGING THE FLEXIBLE GAS HOSE

In order to guarantee that the gas hose is always in excellent condition we strongly recommend changing it on the date you will find printed on it.

REPLACING THE ELECTRICAL COMPONENTS

- The rear protection will have to be removed in order to change the electrical heating elements, spit motor, terminal board and power cable.
- **If you have to change the power cable (see the cross section on table on page 25), always keep the earth wire longer than the phase wires and, in addition, follow all the instructions given in the “ELECTRICAL CONNECTION” paragraph.**
- To change the oven lamp see the instructions on page 14.
- To change the lamp holder, the spark generator and the spark electrodes, the work top has to be removed as indicated in the paragraph «**REPLACING THE TAPS**».
- **To change the lamp-holder (fig. 10)**, unscrew the protective glass cap (C), force the tabs of blockage and take the lamp-holder toward the inside of the oven.
- To change the programming accessory, thermostat, the commutator and the warning lights, remove the front panel as indicated in the paragraph «**REPLACING THE TAPS**».

TECHNICAL FEATURES

BURNER DISPOSITION

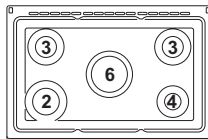

BURNER TECHNICAL DATA TABLE

N.	BURNER DENOMINATION	GAS	OPERATING PRESSURE kPa	DIAMETER INJECTORS 1/100 mm	RATING MJ/h
2	Large Left front	Propane	2.75	88	10.0
		Natural	1.00	142	10.0
3	Medium Right rear	Propane	2.75	73	7.2
		Natural	1.00	120	7.2
3	Medium Left rear	Propane	2.75	73	7.2
		Natural	1.00	120	7.2
4	Small Right front	Propane	2.75	54	3.8
		Natural	1.00	90	4.0
6	Wok Center	Propane	2.75	105	14.6
		Natural	1.00	175	15.0

ELECTRICAL COMPONENTS

DESCRIPTION	NOMINAL DATA
Lower heating element of the oven	2100 W
Top heating element of the oven-grill	2000 + 2200 W
Rear heating element	3000 W
Grill heating element	2000 W
Oven lamp	15 W - E 14 - T 300
Fan of the rear heating element	25..29 W
Power cable	H05 RR-F 3 x1.5 mm ²

TECHNICAL DATA	MODEL: IOC9SE3	
	NATURAL	PROPANE
Operating pressure gas	1.00 kPa	2.75 kPa
Total input gas	43.4	42.8
ELECTRICAL		
Voltage	240 V~	
Frequency	50 Hz	
Total rating electrical	3200 W - 15 amp	

SPACE RESERVED

FOR THE APPLICATION

OF THE ELECTRICAL WIRING DIAGRAM LABEL



PRODUCT SERVICE PHONE NUMBER

1800 805 300