

FLAT CANOPY

900mm

IAF9SE3



- 1000m³/h
- 3 Speed fan
- Halogen lights
- Ducted or recirculated
- 65dB(A)
- Stainless steel

features

specifications

Airflow:	1000m ³ /hr Air flow
Noise level:	65 dBA on maximum setting
Lighting:	2 x 20 watt halogen
Power:	240 volt / 50Hz (fitted with 10amp, 3 pin plug)
Ducting Spigot size:	150mm

Optional carbon filters for re-circulating use - Model no. CF260

Optional extension flue cover - Model no. IAFXSE1

*Re-circulating kit IA150BRK required. Order at time of purchase.

dimensions

Product Dimensions: 900mm (W) x 540-1020mm (H) x 500mm (D) *panel*

Cut Out Dimensions: Minimum required height is 650mm when mounting above gas cooktops and 600mm when mounting above electric cooktops

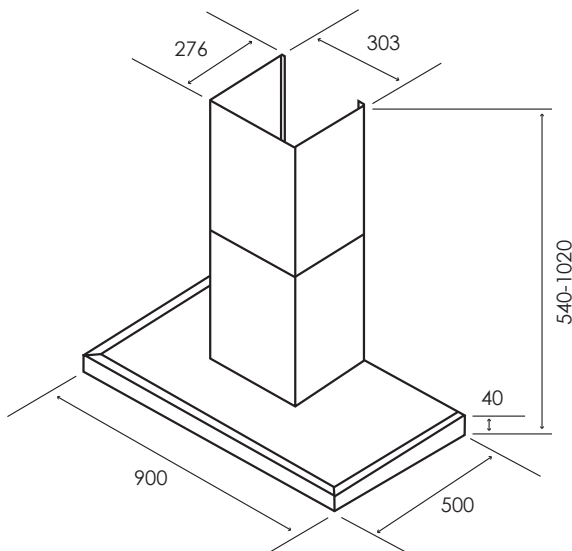

warranty - customer service

Warranty

2 years Parts and Labour

Customer Service

Our Nationwide Service Team can be contacted on our Toll Free Customer Service Number 1800 805 300 or by logging on to <http://customersupport.hapl.com.au/>

 HOME APPLIANCES

20 Carlotta Street
 Artarmon NSW 2064
 T: 02 9958 3111
 F: 02 9958 3555
 E: info@hapl.com.au

www.hapl.com.au