

GEMG28TK

Built-In Microwave 600mm

Features

- 8 Auto cooking menus
- Digital control
- 28 litre capacity
- 900W microwave power
- 1000W grill power
- Speed cooking function
- Stainless Steel Cavity
- Anti fingerprint finishing
- Child safety lock

Stainless steel front panel & trim kit

Silver housing cabinet

18.5kg

Standard Accessories

- Glass turntable
- Chrome grill rack

Product Dimensions

595mm (W) x 388mm (H) x 410mm (D) including trim kit

2 Year Warranty

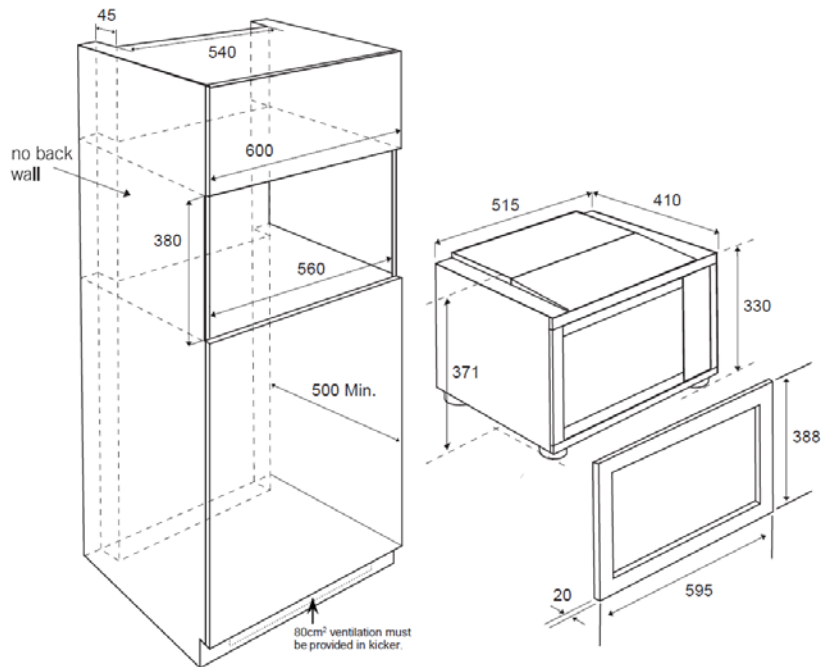

Under Bench Installation

IMPORTANT: Cabinet housing Microwave Oven must have improved air flow to avoid overheating of the appliance – See minimum requirements below

