

# CANOPY RANGEHOOD

# 900mm

## CP9BLB



- Black
- 700m<sup>3</sup>/hr
- Ducted operation
- Re-circulating operation optional\*
- 3 speed fan, electronic backlit button
- 3 x Baffle filters for easy cleaning (dishwasher safe)
- 2 x 3 watt LED lamps cooler and longer lasting

**features**

### specifications

|                             |  |                        |         |
|-----------------------------|--|------------------------|---------|
| <b>Airflow:</b>             | 700m <sup>3</sup> /hr                                | <b>Carbon Filter:</b>  | CF110   |
| <b>Noise level:</b>         | 57 dBA on maximum setting                            | <b>Extension Flue:</b> | IAPXBE1 |
| <b>Lighting:</b>            | 2 x 3 watt LED                                       |                        |         |
| <b>Total wattage</b>        | 196 Watts  |                        |         |
| <b>Power:</b>               | 220 -240 volt / 50Hz (fitted with 10amp, 3 pin plug) |                        |         |
| <b>Power Cord:</b>          | 1.5 metre cable                                      |                        |         |
| <b>Ducting Spigot size:</b> | 150mm  |                        |         |
| <b>Recirculating Kit*:</b>  | IA150BSRK  |                        |         |

### dimensions

**Product Dimensions** 900mm (W) x 645-1025mm (H) x 500mm (D)

warranty - customer service

*Optional carbon filter code AXFC1*

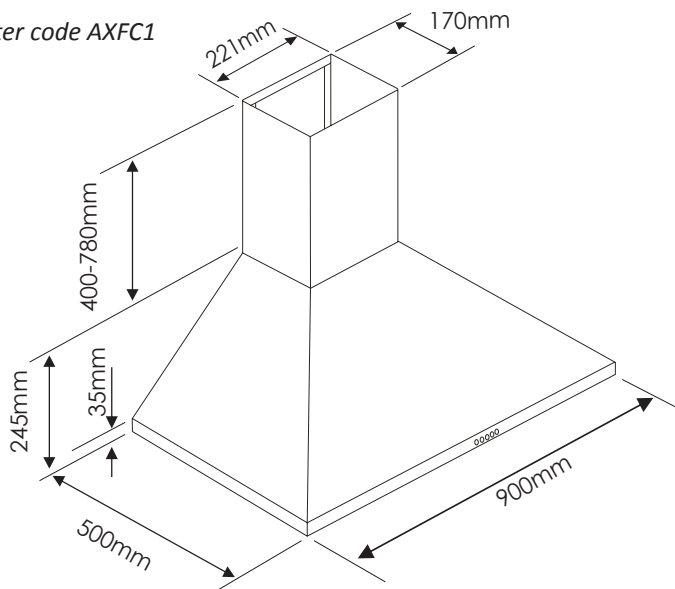

#### Warranty

2 years Parts and Labour

#### Customer Service

Our Nationwide Service Team can be contacted on our Toll Free Customer Service Number 1800 805 300 or by logging on to <http://customersupport.hapl.com.au/>

 **HOME APPLIANCES**

20 Carlotta Street  
Artarmon NSW 2064  
T: 02 9958 3111  
F: 02 9958 3555  
E: info@hapl.com.au

[www.hapl.com.au](http://www.hapl.com.au)