

# FLAT CANOPY

# 900mm

## CF9BLS



- Stainless Steel
- 1000m<sup>3</sup>/hr
- Ducted operation
- Re-circulating operation optional\*
- LED touch control
- 3 speed fan
- 3 x Baffle filters for easy cleaning - dishwasher safe
- 2 x 3 watt LED lamps cooler and longer lasting

features

## specifications

<b>Airflow:</b>	1000m <sup>3</sup> /hr	<b>*Re-circulating Kit:</b>	IA150BRK
<b>Noise level:</b>	65 dBA on maximum setting	<b>Extension Flue:</b>	IAFXSE1 (900mm)
<b>Lighting:</b>	2 x 3 watt LED lamps	<b>Carbon Filter:</b>	CF260
<b>Total wattage</b>	270 Watts		
<b>Power:</b>	220 -240 volt / 50Hz (fitted with 10amp, 3 pin plug)		
<b>Power Cord:</b>	1.5 metre cable		
<b>Ducting Spigot size:</b>	150mm		

## dimensions

**Product Dimensions** 900mm (W) x 560-1040mm (H) x 500mm (D)

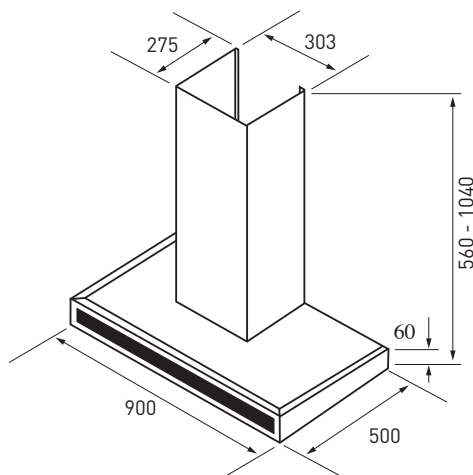

warranty - customer service

### Warranty

2 years Parts and Labour

### Customer Service

Our Nationwide Service Team can be contacted on our Toll Free Customer Service Number 1800 805 300 or by logging on to <http://customersupport.hapl.com.au/>

 **HOME APPLIANCES**

20 Carlotta Street  
 Artarmon NSW 2064  
 T: 02 9958 3111  
 F: 02 9958 3555  
 E: [info@hapl.com.au](mailto:info@hapl.com.au)

[www.hapl.com.au](http://www.hapl.com.au)