

# FREESTANDING DISHWASHER

## 600mm

### ADF6SE2



- 12 Standard settings
- Electronic push button controls
- Slim style control panel
- 3hr, 6hr and 9hr delay start
- Quick height adjust top basket
- 3 piece cutlery basket
- Aquasafe inlet system
- Stainless steel tub and inner door

features

### specifications

<b>Total Load:</b>	2.1W (15amp connection)
<b>Water Usage:</b>	15.7 litres (maximum)
<b>Wels star rating:</b>	2.5 Star
<b>Energy rating:</b>	2.5 Star
<b>power:</b>	220-240 volt/50Hz
<b>Noise Level:</b>	55dB(A)

### dimensions

**Product Dimensions:** 600mm (W) x 580mm (D) x 850 - 900mm (H)

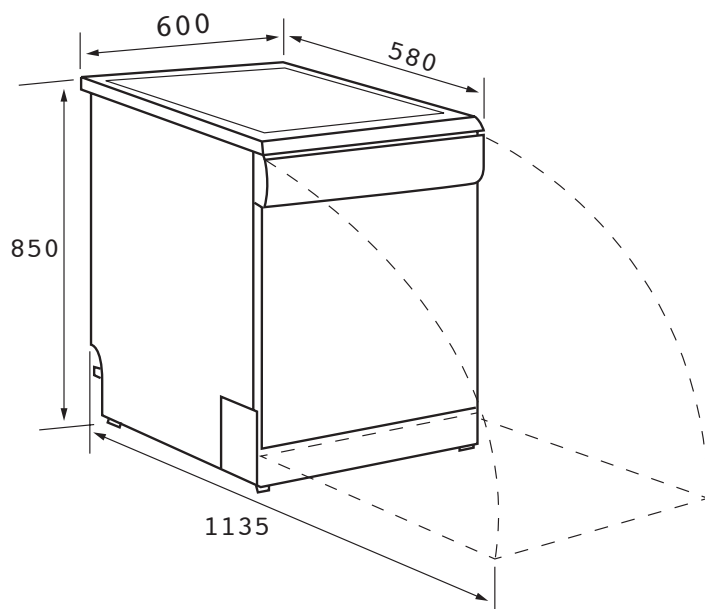

warranty - customer service

#### Warranty

2 years Parts and Labour

#### Customer Service

Our Nationwide Service Team can be contacted on our Toll Free Customer Service Number 1800 805 300 or by logging on to <http://customersupport.hapl.com.au/>

**HOME APPLIANCES**

20 Carlotta Street  
 Artarmon NSW 2064  
 T: 02 9958 3111  
 F: 02 9958 3555  
 E: [info@hapl.com.au](mailto:info@hapl.com.au)

[www.iagappliances.com.au](http://www.iagappliances.com.au)