

RANGEHOOD

900mm

AAS9SE3



- Stainless Steel
- Push Button
- 3 speed
- 3 x Aluminium Grease Filters
- 2 x halogen lights
- Ducted or recirculating operation*

features

specifications

Airflow:	700 m ³ /hr
Sound level:	57 dB (A)
Ducting Spigot:	150mm ducting refer to website for choices
Extension Flue:	IASXSE3 - 900mm in length
Cable:	Insulated 1.5metre cable
Power:	240V/50Hz

*Optional
Carbon Filters for recirculating use Model CF110
Recirculating Kit IA150BSRK

dimensions

Product Dimensions: 645-1025mm (h) x 900mm (w) x 500mm (d)

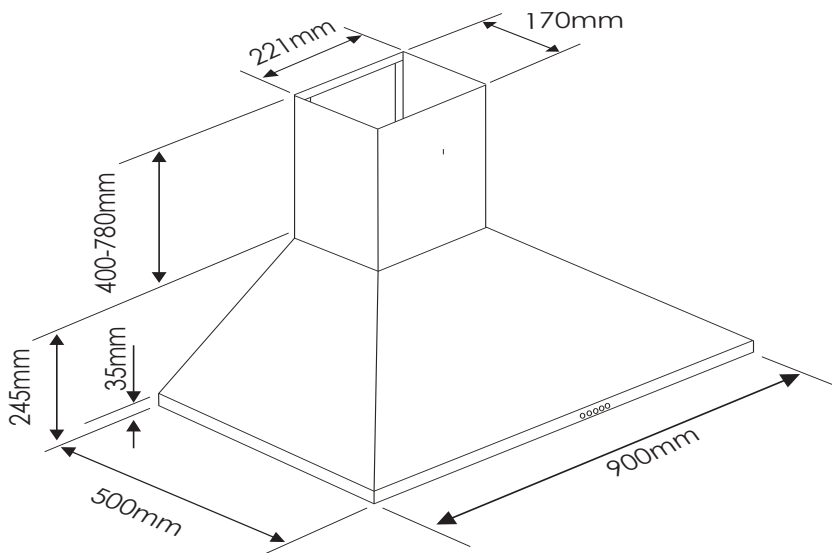

warranty - customer service

Warranty

2 years Parts and Labour

Customer Service

Our Nationwide Service Team can be contacted on our Toll Free Customer Service Number 1800 805 300 or by logging on to <http://customersupport.hapl.com.au/>

 **HOME APPLIANCES**

20 Carlotta Street
Artarmon NSW 2064
T: 02 9958 3111
F: 02 9958 3555
E: info@hapl.com.au

www.hapl.com.au