

Multi Function Programmable Oven Side hinged door

MODEL: IOH6SE1



INSTALLATION AND OPERATION MANUAL

The appliance was designed and made in accordance with the European standards EN 60 335-1 and EN 60 335-2-6 (electrical) plus relative amendments.

The appliance complies with the prescriptions of the European Directives as listed below:

- 73/23 + 93/68 EC concerning electrical safety (BT).
- 89/336 + 92/31 + 93/68 EC concerning electromagnetic compatibility (EMC)

and reports on both its label and its packaging the symbol .

Oven accessories that could come into contact with foods are made with materials that comply with the provisions of the 89/109 EC directive dated 21/12/88.

This product complies with EU Directive 2002/96/EC.

The crossed-out dustbin symbol reported on the appliance indicates that the appliance must be disposed of separately from other domestic refuse at the end of its useful life. It must therefore be delivered to a waste recycling centre specifically for electric and electronic equipment or returned to the retailer at the moment of purchase of a new equivalent appliance.



The user is responsible for delivering the appliance to the appropriate collection centre at the end of its useful life. Failure to do so may result in a fine, as provided for by laws governing waste disposal.

Differential collection of waste products for eventual recycling, treatment and environmentally friendly disposal helps reduce possible negative effects on the environment and health, and also enables the materials making up the product to be recycled.

For more detailed information on the available refuse collection systems, refer to the local Municipal Solid Waste disposal centre or the shop where the product was purchased.

Producers and importers are responsible for fulfilling their obligations as regards recycling, treatment and environmentally friendly disposal by directly or indirectly participating in the collection system.

CONTENTS

1. IMPORTANT NOTES AND PRECAUTIONS FOR USE	3
2. DESCRIPTION OF THE APPLIANCE	4-6
3. INSTRUCTIONS FOR THE USER	7-12
4. TROUBLESHOOTING	12
5. INSTRUCTIONS FOR THE INSTALLER	13-14
6. TECHNICAL FEATURES	15
7. ASSISTANCE AND SPARE PART	15

1. IMPORTANT NOTES AND PRECAUTIONS

You have purchased one of our appliances for which we thank you. We are confident that this modern, functional and practical new model, produced with top quality materials, will meet all your expectations. Although this appliance is very simple to use, **we strongly recommend reading this handbook thoroughly and carefully.** It provides information for safe installation, use and maintenance. Keep this handbook in a safe place for future reference.

The manufacturer reserves the right to make modifications to its products that it deems necessary or useful, or to meet the consumer interest, without prejudicing its essential functional and safety characteristics.

The manufacturer cannot be held responsible for any inaccuracies due to printing or transcription errors that may be found in this handbook.

N.B.: the illustrations shown in this handbook are purely indicative.

- **The installation and maintenance listed in the section “5” must be carried out exclusively by qualified personnel.**
- The appliance must only be used for its original purpose, that is, cooking for domestic use. Any other use is considered improper and, as such, dangerous. The manufacturer cannot be held responsible for any damages to persons or properties resulting from incorrect installation, maintenance or use of the appliance.
- Once all external and internal packaging/ wrappings have been removed, check that the appliance is intact. In case of doubt, do not use the appliance and turn to qualified personnel.
- All packaging materials used (cardboard boxes, bags, polystyrene foam, nails, etc.) must be kept out of the reach of children, as they are a potential hazard source. All packaging materials used are environmentally-friendly and recyclable.
- The electrical safety of this appliance is only guaranteed if it is correctly connected to a suitable earth system, as prescribed by the electrical safety standards. The manufacturer disclaims all responsibility if these instructions are not followed. Should you have any doubts, seek the assistance of a qualified electrician to test your electricity plant.
- Before plugging in the appliance, make sure that the rating data label complies to that of the electricity mains.

A list of few basic rules that must be observed when using any kind of electrical appliance:

- # Never touch any electrical appliance if hands or feet are wet or damp.
- # Never use the appliance bare footed.
- # Do not pull the power lead to force the plug out of the socket.
- # Never leave the appliance in the outside weather conditions.
- # Do not allow children or unskilled hands to use the appliance unattended.
- Before cooking for the first time, ensure the oven is empty and its door closed, heat the oven at maximum temperature for about 2 hours to ensure all bad smells deriving from packaging are gone. Ensure adequate ventilation during this process.
- During cooking and for a while after use, the crystal glass of the oven door and accessible parts can be very hot, so keep children at a distance.
- Keep the appliance clean. Food deposits can cause fire risk.
- Avoid using the oven as a larder or as a saucepan cupboard when you are not using it for cooking: if the oven is turned on accidentally it could cause damage and accidents.
- If you are using an electrical socket near the appliance, make sure that the cables are not touching the oven and are far enough away from all hot parts.
- Once you have finished using the oven make sure that all controls are turned off or in closed position.
- Before proceeding with cleaning or servicing your oven, unplug it from the socket.
- In the case of a failure or malfunction, turn the oven off and unplug it. Avoid trying to fix it. All repairs and fine-tuning must be carried out with maximum care and the proper attention of a qualified person. For this reason we recommend you to report to your the nearest Service Centre explaining the trouble you are facing and details of your appliance.

2. DESCRIPTION OF THE APPLIANCE

GENERAL DESCRIPTION

To prevent the oven from overheating it has been equipped with a safety temperature device, which automatically turns on in case the main thermostat fails to work. In such an event, the electricity is temporarily cut off: **do not try to fix the failure yourself, instead turn the appliance off and report to your local Dealer or Service Centre.**

Furthermore, the appliance is fitted with a cooling fan to cool the front control panel, the knobs, the oven door handle and the electrical components.

The cooling fan can turn on automatically when you switch on the oven and turns off when the appliance has switched off:

The oven walls are equipped with guide bars which allow for housing a number of accessories, **the type and the quantity of which may vary depending on the model (fig. 2):**

- Oven shelf (A)
- Drip pan or drip tray (fig. B)
- Pastry or pizza oven tray (C)

The oven is fitted with «push push» knobs.

In order to use the oven, it is necessary to extract the knobs: push and release on them (see fig. 3 and 4).

During use of the oven, ensure that all the knobs are in the external position.

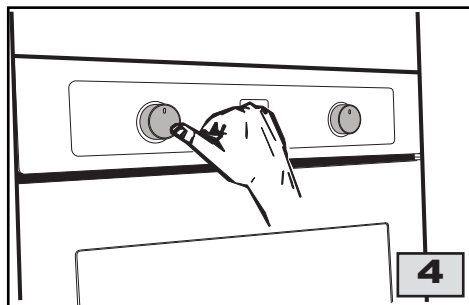
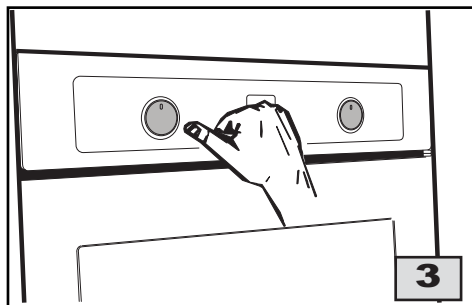
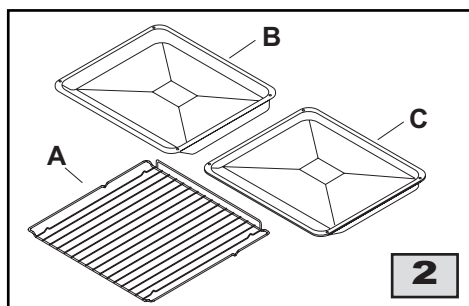
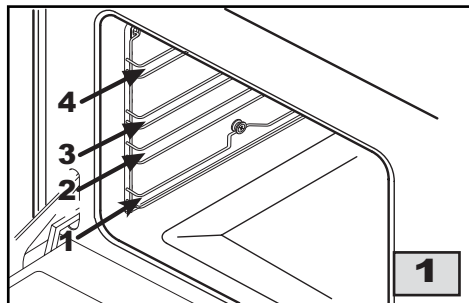

2. DESCRIPTION OF THE APPLIANCE

MODEL: IOC9SE3.

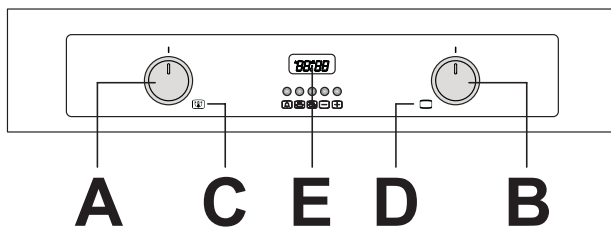

CONTROL PANEL

- A. Oven thermostat knob
- B. Function selector knob
- C. Yellow warning light indicating oven thermostat activation
- D. Red warning light indicating oven electrical components on
- E. Digitale programme









CONTROLS

THERMOSTAT KNOB (ref. A)

By turning the oven knob clockwise we will find the different oven temperature values (from 50°C to Max).

FUNCTION SELECTOR KNOB (8) (ref. B)

By turning the knob to the right or to the left we will find the following symbols:

- 0 = Oven off
-  = Oven light on, which stays on for all functions
-  = Defrost
-  = Top and bottom heating elements
-  = Top and bottom heating elements and fan
-  = Bottom heating element and fan
-  = Fan forced heating element and fan
-  = Grill heating element
-  = Grill heating element and fan

YELLOW WARNING LIGHT (ref. C)

When lit it indicates that either the electric oven or electric grill is working. While the oven is being used the light will switch off when the set temperature is reached. During baking it is normal for the yellow light to switch on and off several times as the oven temperature is controlled.

RED WARNING LIGHT (ref. D)

When lit it indicates that the electric grill or one of the oven electric components is on.

2. DESCRIPTION OF THE APPLIANCE

DIGITAL PROGRAMME (fig. E)

This accessory operates the following features:

- Clock (set by keys 2 and 3)
- Timer (set by key 1)
- Cooking time (set by key 2)
- End of cooking time (set by key 3)
- Manual operation settings (set by keys 2 and 3)
- Setting time backwards (set by key 4)
- Setting time forward (set by key 5)

The digital display always shows the time and can be set to show cooking time or end of cooking count-down simply by pressing the corresponding key.

Please Note: When the cooking session is over the programme automatically turns off the oven (except for the timer). Should you wish to proceed manually next time you use the oven, make sure you set the manual operation function (see instructions further on).

Time setting (0:01 to 24:00 = hh,mm)



When plugging in the appliance the first time or subsequent a power cut, the display shows both "A" and "0.00" (or the minutes past the power failure) signs flashing.

To reset the time push keys 2 and 3 simultaneously then press key 4 or 5 till you reach the exact current time. When done, the "A" symbol turns off and the manual operation symbol  is lit.



Manual operation

Each time the time is set, the programme sets automatically on manual working order. The only other case when this occurs is when an automatic programme reaches completion, or has been cancelled by pressing keys 2 and 3 at the same time. The "A" symbol disappears and the  turns on.



Timer setting (0:01 to 0:59 = hh,mm)

Press key 1 and select cooking time by pushing key 4 or 5. Symbol  turns on. Once the time set is expired the acoustic alarm rings and  turns off.





Semi-automatic working order (cooking period from 0:01 to 23:59 = hh,mm)

Press key 2 and set cooking time by keys 4 or 5; both symbols "A" and  are lit. Once the set period is over,  turns off, "A" flashes and the buzzer rings.

Semi-automatic working order (setting end of cooking from 0,01 to 23,59 = hh,mm)

Press key 3 and set the end of your cooking session by key 5; both symbols "A" and  turn on. Once the set hour is reached,  turns off, "A" flashes and the buzzer rings.

Automatic operation (with a delayed start)

Set the cooking period first ("A" and  turn on) then set the end of cooking time ( turns off) as previously described. Symbol  turns on again when at the start of cooking session. When cooking time is over,  turns off, "A" flashes and the buzzer will advise cooking completion.

Buzzer

The buzzer starts ringing when a cooking session has reached its completion or the timer countdown is over. It can ring up to 7 minutes. Press any function key to make it stop beforehand.

Programme start and control

The programme starts immediately after setting. To check settings of the programme press the corresponding key.

Modify or Cancel programme setting

In case the current time displayed on the clock is within the cooking period set, an error in the automatic function occurs, and both the buzzer ring and the flashing «A» draw your attention. Such error in the set up can be amended by varying the cooking time length or its end. Any programme set can be modified at any time by pressing first its corresponding programme key and then key 4 or 5. To cancel a programme, correct the time set bringing it to a value of "0.00". When functioning time is cancelled the end of functioning is cancelled too and vice versa. The oven turns off automatically and the "A" symbol flashes.

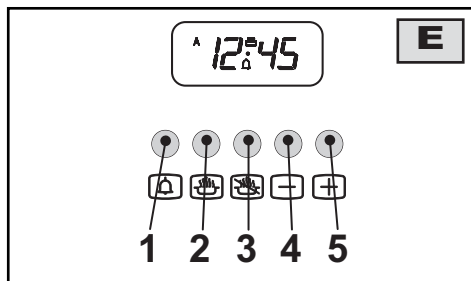

3. INSTRUCTIONS FOR THE USER

GENERAL NOTES ON SAFETY

- Never leave the oven unsupervised when cooking. Make sure that children do not play with the appliance.
- Do not spray aerosols in the vicinity of this appliance while it is operating.
- Where this appliance is installed in marine craft or in caravans, it shall not be USED AS A SPACE HEATER.
- To open the oven door, grab the door handle at its middle. Avoid forcing the oven door when it is open.
- Do not worry if steam condensation accumulates on the door and on the inside walls of the oven during use. This does not affect its working order.
- Mind hot steam when opening the oven door.
- The appliance becomes very hot during use. Do not touch the heating elements inside the oven. Wear oven gloves when placing or removing pans from the oven.
- In placing foods into or removing them from the oven, make sure sauces do not drip onto the hot plate of the oven (overheated oils and fats can easily ignite).
- Use only ovenware resistant to the temperature range indicated on the thermostat knob.
- During baking, avoid covering the bottom plate of the oven or its grid with tin foil or other material. Saucepans, oven trays and all other ovenware must always be placed on the oven grid.
- After use of the appliance, make sure that all the controls are set to the off or closed positions.
- **IMPORTANT WARNING:** During and after use the oven crystal door and all surfaces may be very hot. Keep children away from the oven!

IMPORTANT!! The oven door must stay closed when using both the oven and the grill.

WHAT TO DO THE FIRST TIME YOU USE THE OVEN

If the appliance has a programming accessory, place it on the manual position, and, before cooking for the first time, ensure the oven is empty and its door closed, heat the oven at maximum temperature for 2 hours. This will allow the protective coating on the interior of the oven to be burnt off and dissipate the associated smells. During this time do not stay in the same room and keep it aerated.

After the hour or so has elapsed leave the oven to cool down and then clean its interior with hot water and a mild detergent. Also wash the accessories (shelves, trays, drip pan, spit..) prior to use.

Prior to any cleaning, disconnect the appliance from the electricity mains.

For your information you will find a brief description of different cooking methods:

- on pag. 8 electric multifunction oven and electric grill to forced convection
- on page 9, some practical tips to get the best results
- on page 10 you will find the tables for baking and grilling.

3. INSTRUCTIONS FOR THE USER

HOW TO USE THE MULTIFUNCTION OVEN



DEFROSTING AT ROOM TEMPERATURE

Turn the selector knob (fig. B) to the symbol and place the food you want to defrost inside the oven. The length of time required depends on the quantity and type of food.

Selecting this function will only activate the fan. Mild air circulation around frozen food will slowly defrost it. It is particularly suitable for fruit and cakes.



TRADITIONAL COOKING

Turn the selector knob (fig. B) to the symbol and adjust the thermostat knob (fig. A) to suit the desired temperature. If pre-heating is recommended wait till the thermostat yellow led turns off before placing foods inside the oven. This option turns on both bottom and top heating units, evenly distributing heat on your foods.

This type of cooking is ideal for all kind of foods (meats, fish, bread, pizzas, cakes..).



COMBINED TRADITIONAL + FAN COOKING

Turn the selector knob (fig. B) to the symbol and adjust the thermostat knob (fig. A) to suit the desired temperature. If pre-heating is recommended wait till the thermostat yellow led turns off before placing foods inside the oven. This option turns on both bottom and top heating units, and heat is distributed by fan ventilation.

This combination is suitable for rapid cooking and allows for the use of more plates positioned on the different levels of the oven (fig. 5).



DEFROSTING + WARM UP BY HOT AIR

Turn the selector knob (fig. B) to the symbol and set the temperature on the thermostat knob (fig. A), now place the food inside the oven. Selecting this function will activate the bottom heating unit and its heat is distributed by the fan. This function is particularly recommended to defrost and warm up ready-made meals.



FAN + REAR HEATING COMBINED COOKING

Turn the selector knob (fig. B) to the symbol and set the thermostat (fig. A) to the desired temperature, then place your food in the oven. If oven needs pre-heating wait till the thermostat yellow led turns off before placing foods inside it. This function activates the rear heating unit and the fan distributes the heat produced. This combination allows for a fast and even cooking of several different foods placed on the diverse levels of the oven (fig. 5).



CONVENTIONAL GRILL COOKING

Turn the selector knob (ref. B) to the symbol and set the thermostat (ref. A) to the desired temperature. Selecting this function the top central heating element turns on and heat is distributed directly on food surface. Apart from grilling, this function is ideal to add a golden roast to your recipes or to toast bread slices.

When you use the grill, **do not forget to place the drip pan beneath it to collect any sauce dripping**, as suggested in the "USEFUL COOKING TIPS" section.



FAN GRILL COOKING

Turn the selector knob (fig. B) to the symbol and set the thermostat (fig. A) to the desired temperature (200°C max). Selecting this function the top central heating element turns on and heat is distributed by the fan. This procedure mitigates the direct heat on food surface and uses milder temperatures. It is therefore recommended for an even golden and crispy finish touch, ideal for whole fish and poultry.

When you use the grill, **do not forget to place the drip pan beneath it to collect any sauce dripping**, as suggested in the "USEFUL COOKING TIPS" section.

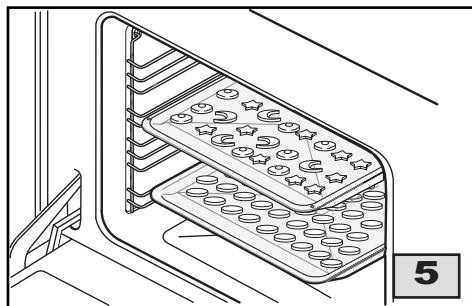

3. INSTRUCTIONS FOR THE USER

USEFUL COOKING TIPS

Cakes and bread:

- Heat the oven for at least 15 minutes before you start cooking bread or cakes.
- Do not open the door during baking because the cold air would stop the yeast from rising.
- When the cake is cooked turn the oven off and leave it in for about 10 minutes.
- Do not use the enamelled oven tray or drip pan, supplied with the oven, to cook cakes in.
- How do you know when the cake is cooked? About 5 minutes before the end of cooking time, put a cake tester or skewer in the highest part of the cake. If it comes out clean the cake is cooked.
- And if the cake sinks? The next time use less liquids or lower the temperature 10°C.
- If the cake is too dry: Make some tiny holes with a toothpick and pour some drops of fruit juice or spirits on it. The next time, increase the temperature 10°C and set a shorter cooking time.
- If the cake is too dark on top: the next time put the cake on a lower shelf, cook it at a lower temperature and longer.
- If the top of the cake is burnt: cut off the burnt layer and cover with sugar or decorate it with cream, jam, confectioner's cream, etc..
- If the cake is too dark underneath: the next time place it on a higher shelf and cook it at a lower temperature.
- If the cake or bread is cooked nicely outside but is still uncooked inside: the next time use less liquids, cook at a lower temperature and longer.
- If the cake will not come out of the tin: slide a knife around the edges, place a damp cloth over the cake and turn the tin upside down. The next time grease the tin well and sprinkle it with flour or bread crumbs.
- If the biscuits will not come away from the baking tray: put the tray back in the oven for a while and lift the biscuits up before they cool. The next time use a sheet of baking parchment to prevent this happening again.

Meat:

- If, when cooking meat, the time needed is more than 40 minutes, turn the oven off 10 minutes before the end of cooking time to exploit the residual heat (energy saving).
- Your roast will be juicier if cooked in a closed pan; it will be crispier if cooked without a lid.
- Normally white meat, poultry and fish need medium temperatures (less than 200°C).
- To cook "rare" red meats, high temperatures (over 200°C) and short cooking times are needed.
- For a tasty roast, lard and spice the meat.
- If your roast is tough: the next time leave the meat to ripen longer.
- If your roast is too dark on top or underneath: the next time put it on a higher or lower shelf, lower the temperature and cook longer.
- Your roast is underdone? Cut it in slices, arrange the slices on a baking tray with the gravy and finish cooking it.

Grilling:

- Sparingly grease and flavour the food before grilling it.
- Always use the drip pan to catch any dripping from the meat during grilling, slide it in one of the levels underneath the grill (fig. 6) or place it at the bottom of the oven. Always pour a little water in the drip pan. It will prevent grease and sauces from burning avoiding burnt smells and smoke. Add more water during cooking to compensate for evaporation.
- Turn the food upside-down when half way through cooking.

The aluminium can be easily corroded if it comes into contact with organic acids present in the foods or added during baking (vinegar, lemon juice). Therefore it is advised not to put directly the foods on aluminium or enamelled trays, but ALWAYS use the proper oven paper.

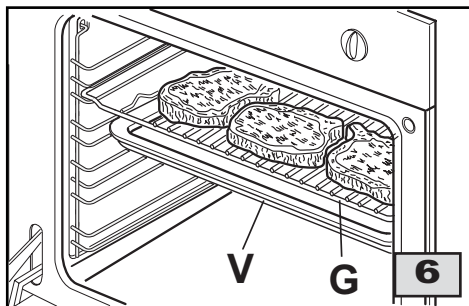

3. INSTRUCTIONS FOR THE USER

COOKING / BAKING TIMETABLE

FOODS	Weight kg	Pan or Baking tray	Position of the oven shelf from the bottom	TRADITIONAL OVEN		COMBINED OVEN (fan ventilated)	
				Temperature in °C	Cooking/Baking Time (in minutes)	Temperature in °C	Cooking/Baking Time (in minutes)
MEAT LOAFS							
Roasted Veal	1	1	2	200-220	100-90	200-220	100-90
Roasted Pork	1	1	2	200-220	120-100	200-220	120-100
Roastbeef	1.15	1	1 or 2	220	60	=	=
Roasted Lamb	2	1	1 or 2	230	165	=	=
POULTRY							
Roasted Chicken	1	1	2	200-220	100-90	=	=
Roasted Turkey	6	1	2	220	150	=	=
Roasted Duckling	1.5	1	2	=	=	200-220	150-120
FISH							
Roasted whole fish	1	1	2	200	30-35	=	=
Sea bass	0.6	1	1 or 2	220	30	=	=
	1.15	1	1 or 2	220	45	=	=
PIZZA							
	1	1	2	225-Max	25-30	220	20
	1 x 2	2	1 and 3	=	=	200-220	25-35
BREAD							
	1	1	2	200-220	27-20	=	=
PATISSERY							
Biscuits / Cookies		1	2	180	20-25	190	15
Biscuits		2	1 and 3	=	=	170-190	18-15
Coconut biscuits		2	1 and 3	=	=	170-190	25-20
Lemon biscuits		2	1 and 3	=	=	170-190	27-23
Muffins		2	1 and 3	180	30-35	160-170	30-25
Sweet "bun" rolls		1	2	225	18	=	=
Sweet "bun" rolls		2	1 and 3	=	=	200	16
CAKES/FLANS							
Angel Cake/Sponge	0.8	1	2	190	52	190	45
Apple flan	=	1	2	190	60	=	=
Fruit jam tart/flan	=	1	2	=	=	190	45
Fruit jam tart/flan	=	2	1 and 3	=	=	175-190	50-40
Strudel	=	2 or 3	1	180-190	60-50	=	=
Quiche	=	2 or 3	1	=	=	200-210	55-45

Values indicated in the tables (temperatures and cooking times) are approximate and may vary according to each person's cooking habits.

GRILLING TIMETABLE

FOODS	Weight kg	Nr. of pieces	Position of the oven shelf from the bottom	TRADITIONAL OVEN			COMBINED OVEN (fan ventilated)		
				Temperature in °C	Cooking/Baking Time (in minutes)		Temperature in °C	Cooking/Baking Time (in minutes)	
					1 st side	2 nd side		1 st side	2 nd side
MEAT									
T-bone steak	0,50	2	4	225-Max	12-15	12-15	200	15	10
Steak	0,15	1 or 2	4	200-225	5	5	=	=	=
Chicken (cut in half)	1		3 or 4	225	20	20	=	=	=
FISH									
Trout	0,50	2	4	=	=	=	200	10	10
Sea bass	0,15	1	4	=	=	=	200	10-12	10-12
Sole	1	2	4	=	=	=	200	8-9	8-9

Values indicated in the tables (temperatures and cooking times) are approximate and may vary according to each person's cooking habits. More specifically, when grilling meat cuts the values are subject to the thickness of the slice or loaf and to personal taste as well.

3. INSTRUCTIONS FOR THE USER

CLEANING AND MAINTENANCE

Prior to any maintenance work or cleaning, disconnect the appliance from the electricity mains.

Do not use a steam cleaner to clean this appliance.

EXTERIOR PARTS

All the parts of the oven exterior (stainless steel, side panels, door glass) must be cleaned frequently with a mild detergent and a little water and then dried with a soft cloth.

Do not wash the parts if they are still hot and never use abrasive powders, pads or corrosive spray products.

Do not leave vinegar, coffee, milk, salty water or the juice of lemon or tomato on the surface for any length of time

On painted or stainless steel surfaces, **do not use** aromatic or aliphatic solvents to remove spots or label adhesive.

INTERIOR PARTS

The oven should be cleaned after each use to remove cooking residuals like fats or sugar which, burnt afterwards, can encrust or form permanent stains and unpleasant smells.

The oven should always be cleaned when it is still warm with soapy water, rinsed and dry properly on all surfaces.

Never use abrasive powder cleaners or sponges. Also wash any accessory used.

Do not leave ingredients like vinegar, coffee, milk, salty water, lemon juice or tomato sauce on enamelled surfaces for a long time.

Do not spray or wash the electric heating elements nor the thermostat with acid-based detergents (check the information label on the product you are using). The manufacturer cannot be held responsible for any damages caused by incorrect cleaning.

OVEN SEAL

The condition of the oven seal is vital for the correct functioning and performance of the oven.

We recommend you:

- Clean it, avoiding abrasive tools or products.
- Check its condition occasionally.

In case the seal has stiffened or presents damages, contact your nearest Service centre and avoid using the oven until it has been repaired.

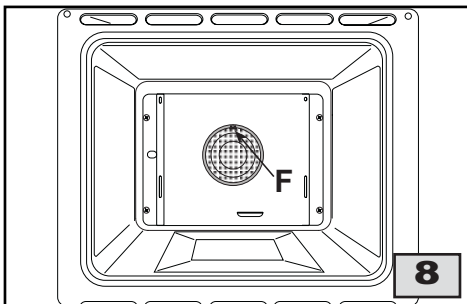
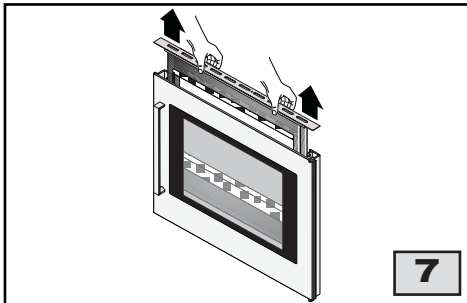

INTERNAL OVEN DOOR GLASS

One of the features of our ovens is that the internal oven door glass can be easily removed for cleaning without the aid of specialized personnel.

Just open the oven door and extract the support to which is attached the glass (see fig. 7).

OVEN FAN FILTER

The oven is fitted with a fan protector filter to prevent excessive airborne fat from clogging the fan.

After each use, we recommend cleaning the filter thoroughly (by hand or in the dishwasher).

To remove, push the tab (F) upwards (fig. 8).

To refit, repeat the above in reverse order, taking care that the rear tabs are seated in the relative holes at the back of the oven.

3. INSTRUCTIONS FOR THE USER

OVEN SIDEWALL GRIDS (fig. 9)

To allow for a better cleaning of the side grids, you can extract them this way:

- Push with a finger on the last of the slots to release the grid from its hold (A).
- Lift it towards the top and extract the grid.

To put them back into place, reverse the order of this operation.

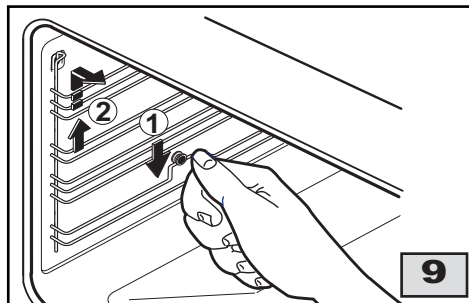

REPLACING THE OVEN LAMP (fig. 10)

Attention!! Before replacing the oven light, disconnect the appliance from the electricity supplies.

If the oven lamp needs replacing the new lamp must have the following characteristics:

15 W - 240 Vac - 50 Hz - E 14 - resistant to high temperatures (300°C).

To substitute the bulbs follow these instructions:

- Extract the side grids as indicated in the previous paragraph.
- Unscrew glass protection cap (V) from bulb holder by lifting it with a screwdriver (C) against the inside wall of the oven.
- Substitute the bulb and reposition all elements back by following the operation in reverse order.

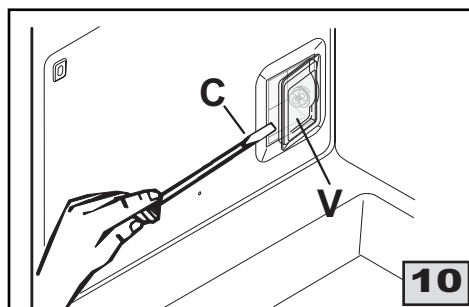

4. TROUBLESHOOTING

Some problems can be caused either as the results of simple maintenance operations or by incorrect selection of settings. Prior to contacting a Service Engineer please check the following chart.

PROBLEM occurring	SOLUTION envisaged
The oven does not work	<ul style="list-style-type: none"> • Check that the plug is connected. • Check that the programmer / clock is set for manual operation. • Check the electrical system (fuse electricity board). If there is failure in the system call an electrician.
During cooking the thermostat led does not turn back on	<ul style="list-style-type: none"> • Turn the thermostat round to a hotter temperature. • Turn the selector round to a different function.
The oven light does not switch on	<ul style="list-style-type: none"> • Turn the selector round to a different function • Check that the oven bulb is properly fitted • If it has blown, buy a bulb specifically for high temperatures at a Service Centre and fit it following the instructions given on page 12.

In case the appliance fails to operate correctly, contact our Service Centre.

Warning: Servicing should be carried out only by authorised personnel.

5. INSTRUCTION FOR THE INSTALLER

TECHNICAL INFORMATION

All instructions related to installation and maintenance operations listed in this section must be carried out only by authorised personnel.

The manufacturer cannot be held responsible for any damage to persons or property resulting from an incorrect installation of the appliance.

UNPACKING YOUR APPLIANCE

- Once the packaging has been removed, thoroughly check that the appliance is in perfect condition. If you have any doubts do not use the appliance and call our Service Centre.
- Do not move the appliance by the handles.
- Some parts mounted on the appliance are protected by a plastic film. This protection must be removed before using the appliance. We recommend slitting the plastic film along the edges with a sharp knife or pin.

All packaging materials used (cardboard boxes, bags, polystyrene foam, nails, etc.) must be kept out of the reach of children, as they are a potential hazard source. All packaging materials used are environmentally-friendly and recyclable (wooden bits are free from chemicals, cardboard is 80-100% recycled, protective bags are made in polyethylene (PE), bands in polypropylene (PP) and padding in polystyrene foam (PS) without chloro-fluoro-carbides. Waste materials can undergo treatment and be recycled saving on new raw materials and on the amount wasted volumes. For this purpose we suggest you take the packaging material back to the shop you bought the appliance or to a collecting service. Ask your local service for the nearest service.

WARNINGS

- As this is a built-in oven, please ascertain that the walls or panels surrounding the appliance can withstand a temperature of over 70 K.
- Also make sure that the glue that joins the laminated plastic coat to the unit can withstand a temperature of around 150°C, to avoid the laminated coat to unglue.

MINIMUM DIMENSIONS OF THE UNIT TO HOUSE THE OVEN (fig. 11)

Height mm	Width mm	Depth mm	Volume dm ³
570	560	550	50

INSTALLING AND FIXING THE OVEN

- The oven can be housed into a cabinet or into a base module, making room for its volumes as shown in fig. 11. **To guarantee proper aeration of the heat remove the rear panel of the base module or make an escape opening (A), as shown in fig. 11.**
- With the oven door closed**, unscrew the inferior screw (fig.12) with a hexagonal key n. 8 (not supplied) and remove the door take off it from the superior pivot.
- Fit the appliance in place and secure it with the screws supplied (V) (fig. 13).
- Reassemble the door inserting it in the superior pivot and then, with the door closed, tighten the inferior screw.

The oven must stand on a solid platform that will withstand its full weight, as screws are only used to secure the appliance inside its cabinet housing.

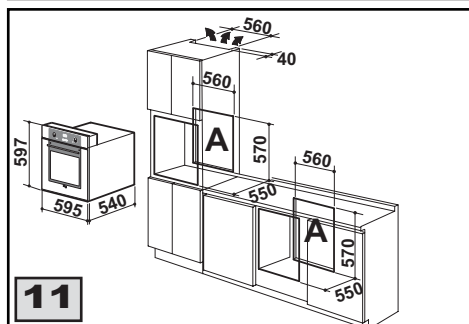

11

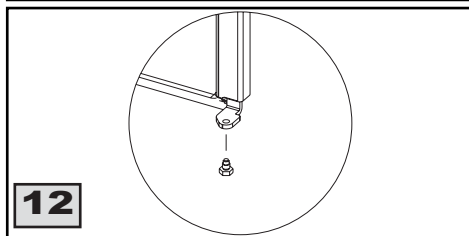

12

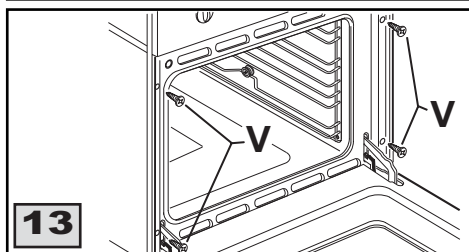

13

5. INSTRUCTION FOR THE INSTALLER

ELECTRICAL CONNECTION

Electrical connection must be carried out in accordance with current standards and normative.

Before connecting the oven check out the following list:

- The system and electrical sockets amperage is adequate for the appliance maximum power (see data label affixed on the back of the oven and in the appliance handbook)
- The socket or system has an effective earth connection in accordance with current standards and prescriptions of the law. All responsibility is disclaimed if this is not complied with.
- The plug and socket or the multipolar switch must be accessible after installation of the appliance.

When connecting to the mains with a socket:

- Fit a standard plug, suitable for the load, which is indicated on the rating plate, to the power cable. Connect the wires making sure they match the indications below. **Pay attention to the earth wire, which must be longer than the phase wires:**

letter L (phase) = brown wire

letter N (neutral) = blue wire

symbol ⊕ (earth) = green/yellow wire

- The power cable must be laid far from heat sources and its temperature should stay below 75°C.
- Avoid using adapters or shunts as they could cause false contacts resulting in hazardous overheating.

When connecting directly to the mains:

- Install a multipolar switch that can withstand the appliance's load, with a minimum opening between the contacts of 3 mm. **Remember that the earth wire must not be cut out by the switch.**

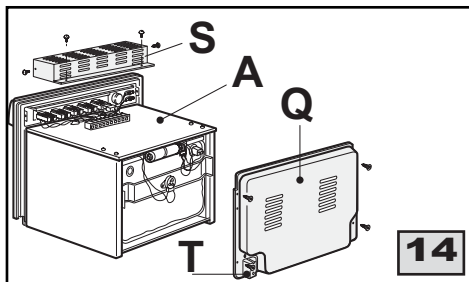

MAINTENANCE

Before replacing any spare parts it is vital to disconnect the appliance from the electricity mains.

REPLACING ELECTRICAL COMPONENTS

- To replace the oven lamp please refer to instructions on page 12.
- To access other electrical components the oven will have to be removed from its housing unit by unscrewing it (V) (see fig. 13). Oven extraction allows access to the terminal board (T)(fig. 14).

If the power cable needs replacing always keep the earth wire longer than the phase wires and do follow all instructions given in the “ELECTRICAL CONNECTION” section.

- Remove the rear protection panel (Q) to have access to the heating elements, temperature limiting device and the fan (fig 14).
- To change lamp holder (P), remove the superior protection (A) and the side panel, then use a screwdriver to push the two locking tabs (fig. 15) and remove the lamp holder from the inside of the oven.
- To replace the thermostat, the commutator, the programmer and the indicator lights, remove protection box (S) (fig. 14). Remove the knobs and undo the screws underneath to free the components that need replacing.

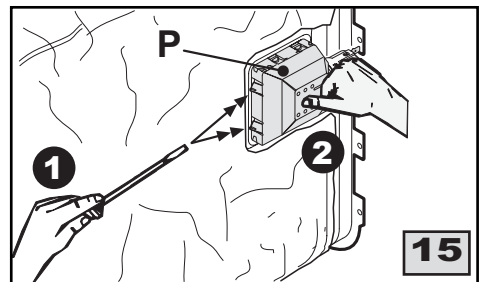

6. TECHNICAL FEATURES

ELECTRICAL COMPONENTS

Description	Nominal data
Lower heating element of the oven	170 + 800 W
Top heating element of the oven-grill	800 + 1800 W
Rear heating element	2000 W
Grill heating element	1800 W
Oven lamp	15 W - E 14 - T 300
Tangential or cooling fan	18..22 W
Fan of the rear heating element	25..29 W
Supply cable	H05 RR-F 3x 1.5 mm ²

7. ASSISTANCE AND SPARE PARTS

Before this appliance left the factory it was tested and fine-tuned by specialised expert personnel in order to guarantee its best functioning results.

Any subsequent repairs or adjustments that may be necessary must be done with the maximum of care and attention by qualified personnel.

For this reason we recommend you always contact your local Dealer or our nearest Service Centre, specifying the brand, the model, its serial number and type of problem you are facing with it. All data related to your appliance are printed the model label at the side of the appliance as well as on its original packaging.

A duplicate data label is contained in this booklet also. Please attach this label on the handbook or to an accessible surface near by the appliance for easy reference. This information enables the technical assistant to come and visit you with the correct spares and guarantee a prompt and suitable service.

You will only find original spare parts at our Technical Assistance Centres and authorised dealers.

SPACE FOR DATA LABEL



PRODUCT SERVICE PHONE NUMBER

1800 805 300