

CANOPIES

FLAT CANOPY 900



Colour:	Stainless Steel
Model:	IAF9SE1
Dimensions:	900mm (W) x 480mm (D) x 456 – 856mm (H)
Packaging:	Carton Size 1097mm (W) x 460mm (D) x 540mm (H) Carton Cubic Metres 0.27 cubic metres Carton Weight 20kg
Motor:	Single 198 watt
Airflow:	Airflow = max. 760m ³
Noise Level:	Max. 56dBA
Controls:	Backlit electronic push button, 3 speed
Features:	Teflon coated blades, oil catchment cup
Lamps:	2 x 10W Halogen
Power Requirement:	240V 10 amps
G.P.O. Location:	Behind flue approx. 2100mm from floor height or 1200mm from benchtop height
Filter:	3 x Aluminium mesh
Recirculating:	Optional 2 x carbon filters (Optional - Code IXFC4 - available to purchase on 1800 805 300).
Ducting:	Top Only (for details refer to the Ducting Specification Sheets under Accessories on the website)
Duct Spigot:	150mm
Maximum Extension of Flue from Floor:	2456mm (Optional - Code IASXSE2 , 900mm flue cover available if required. To purchase call 1800 805 300)
Minimum Height Above Cooktop:	700mm
Method of Installation:	Freestanding, attach to wall
Country of Origin:	China

CANOPIES

FLAT
CANOPY
900

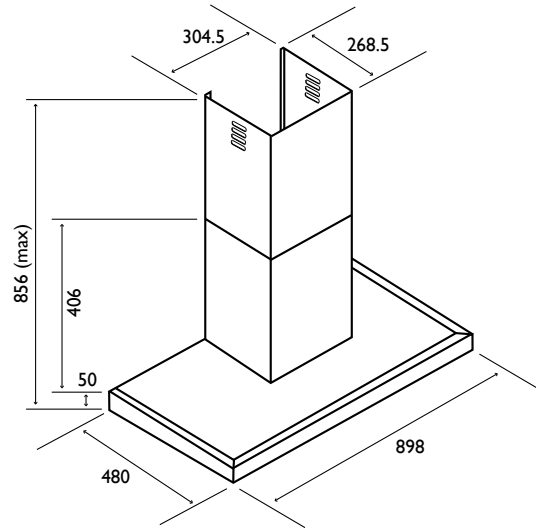

Rear ducted to outside

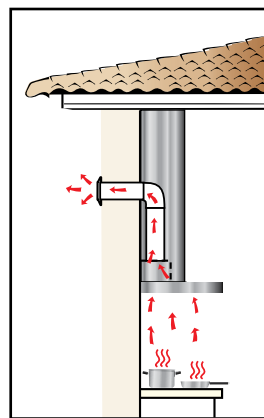

Top ducted to outside

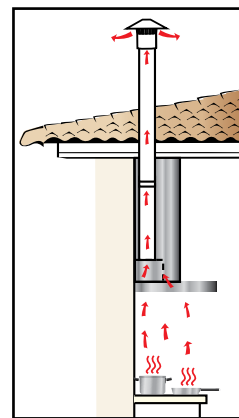

Side ducted to outside

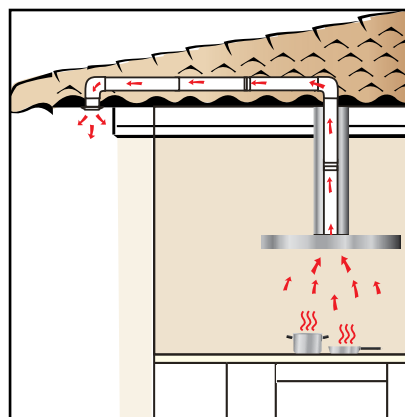

Recirculating Installation

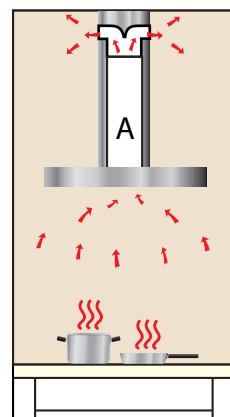

A = Ducting if required