



PRODUCT SERVICE PHONE NUMBER

1800 805 300

Tip. Montagnani - Modena (Italy) - Cod. 534932 0602

Professional Cooking Centre

MODEL: IOC9SE1



INSTALLATION AND OPERATION MANUAL

RECORD HERE FOR EASY REFERENCE

Model..... Colour.....
Serial Number..... Installation Date.....
Dealer's Name and Address.....

GENERAL INFORMATION

ENVIRONMENTAL WARNING

Waste packaging

Do not throw the packaging of your appliance into the dustbin, but pick out the different materials (for instance foil, paperboard, polystyrene) according to the local rules for rubbish elimination.

This appliance must only be used for the purpose of domestic cooking.

Getting to know your new cooker

Thank you for choosing one of our products. Our cookers are of simple, rational design. They are constructed to the best standards to ensure good service and outstanding safety. Please read this manual carefully; it will provide all the advice needed to allow you to obtain the best results from the very first day.

ATTENTION:

- Before using the appliance, do not forget to remove the protecting parts of the appliance.

WHEN YOU CALL FOR SERVICE

When you call for service or order parts for your unit, be sure to give:

1. MODEL
2. SERIAL NUMBER
3. COLOUR
4. PART NAME and/or description of problem
5. YOUR FULL NAME, ADDRESS, and HOME TELEPHONE NUMBER and BUSINESS TELEPHONE NUMBER IF APPROPRIATE.

FOR SERVICE AND SPARE PARTS PLEASE CALL
1800 805 300

SECTION FOR THE QUALIFIED TECHNICIAN

OVERALL DIMENSIONS

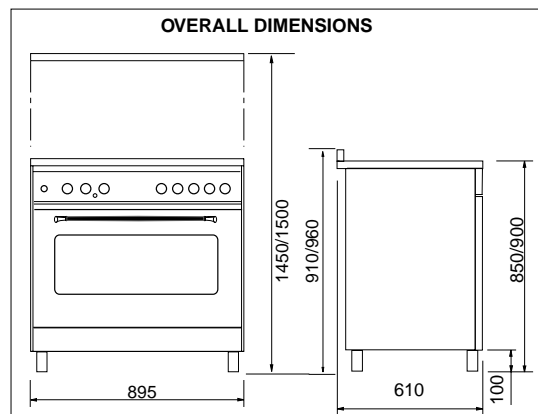

INSTALLATION

PROVISION FOR VENTILATION

The room where the Cooker is installed should have permanent ventilation as follows:

"Ventilation must be in accordance with AS5601/AG 601 - Gas Installations. In general, the appliance should have adequate ventilation for complete combustion of gas, proper flueing and to maintain temperature of immediate surroundings within safe limits:"

- Do not install in a bed-sitting room, a bathroom or shower room. If there is another fuel burning appliance in the same room, a higher level of ventilation will be required, you should consult "the safety requirements".

In addition to the above, during prolonged use, opening a window in the same room is recommended. This will avoid the build up of excessive moisture and condensation.

POSITIONING

Important: Fix the chain located next to the gas connection on both sides of the cooker to the wall to prevent the cooker from tilting. Both chains must be securely fixed. Make sure that the wall surface behind the Cooker is non-combustible (will not catch fire).

Where a painted surface is adjacent, a fire retardant paint surface is recommended. Wallpaper, wood, or fabric should not be used behind or next to the cooker.

"Any adjoining wall surface situated within 200mm from the edge of any hob burner must be a suitable non-combustible material for a height of 150mm for the entire length of the hob. Any combustible construction above the hotplate must be at least 650mm above the maintop." Ensure that a power and gas supply are nearby. The Cooker should be located carefully so that the heat produced by it has plenty of space to escape. The diagram below shows an ideal configuration.

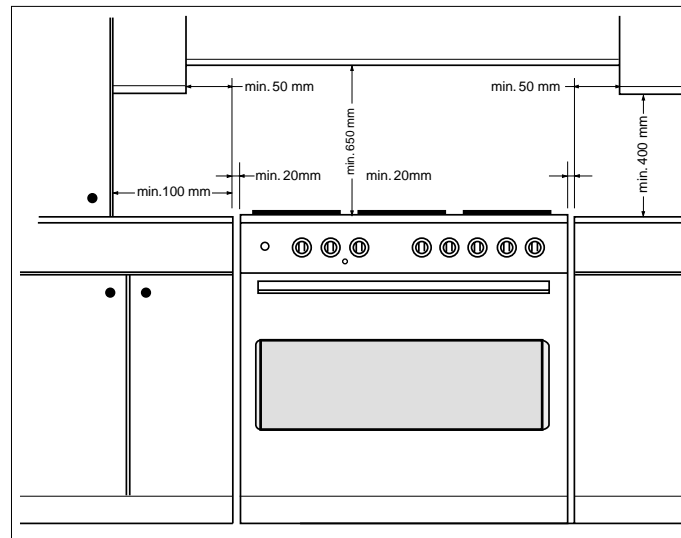

"If the cooker is being fitted next to cupboards or adjoining wall surfaces, which are within 200mm from the edge of the hob burner and of a suitable non-combustible material as specified in AS5601, ensure that a total gap of at least 12cm is left between the edge of the cooker". This gap could be split equally, i.e. 6cm on each side, or unequally, to suit circumstances. This is to allow plenty of space for the heat produced by the hob to escape at each side of it.

Note:

The cooker is fitted with 4 legs for an eventual alignment in height with the furniture. To assemble them, it is necessary to raise the cooker and to screw the four legs into the suitable threadings placed on the corners on the bottom of the appliance.

- hotplate and out of danger, particularly from small children.
- Never leave a chip pan unattended.
- Pans and kettles with down turned base rims should not be used.
- Simmering aids such as asbestos or mesh mats are NOT recommended. They will reduce burner performance and could damage the pan supports.
- Commercially available foil spillage aids are unnecessary on this hotplate.

PROBLEM SOLVER

Any of the following are considered to be abnormal operation and may require servicing:

- Yellow tipping of the hob burner flame.
- Sooting up of cooking utensils.
- Burners not igniting properly.
- Burners failing to remain alight.
- Burners extinguished by oven door.
- Gas valves, which are difficult to turn.

Your Installer should be contacted if you have any problems with the installation.

Before you call a service engineer please check if the problem is something you could fix yourself. The cause of the problem is often a simple one.

THINGS TO TRY BEFORE CALLING FOR AN ENGINEER

Burner does not burn well

Is the burner dirty or damp? Try cleaning and/or drying the burner. Appliance not suitable for your gas type? Check the identification plate on the hotplate base.

Burner does not ignite

Do the burners spark when you press the ignition button? If not is the power on? See 'Checking the power supply' section further on. If the power supply is OK then there is probably something wrong with the ignition system.

Are the electrode or burner slots blocked by debris?
Is the burner dirty or damp? Try cleaning and/or drying the burner.
Is the burner trim correctly located?
Are the burner caps correctly located?
Check that there is not a problem with your gas supply. You can do this by making sure that other gas appliances you may have are working.

Pan supports

Aluminium pans may cause a metallic marking on the pan supports which does not affect the durability of the enamel and may be cleaned off with a metal cleaner such as 'Brasso'.

Checking the power supply

First check the socket by trying out another piece of electrical equipment in it.

If that works, renew the fuse in the hotplate plug. Use a 10 amp fuse. If the fuse 'blows' again there is a fault on the hotplate. Do not use a fuse with a higher rating. Do not carry out other electrical work. Unplug the hotplate and tell your installer.

Power Failure

In the event of a failure in the electrical supply the hotplate burners may be lit using a match.

Ventilation

The use of a gas cooking appliance results in the production of heat and moisture in the room in which it is installed. Ensure that the kitchen is well ventilated: keep natural ventilation holes open or install a mechanical ventilation device, (mechanical extractor hood). Prolonged intensive use of the appliance may call for additional ventilation, for example opening a window, or more

effective ventilation, for example increasing the level of mechanical ventilation where present. For more detail see the Installation Instructions.

OVEN DOES NOT WORK AT ALL

First, when the oven is equipped with timer, check appliance is not programmed to turn on later. If it is, turn to manual setting (i.e. hand symbol). If the button or scale on the timer remains in the automatic position after use, the power supply to the oven will be interrupted. Also, check your appliance is switched on at the mains. Next check for an unexpected power strike by switching on adjacent lights etc. Finally, check fuses and plug wiring. If all these prove satisfactory, call engineer.

LIGHT BULB DOESN'T COME ON

Check bulb for looseness or burned out bulb.
Note: bulb replacement is not covered by your guarantee.

SMOKE COMING FROM OVEN

If oven is still relatively new, this problem is invariably due to protective oil on elements. Otherwise, the answer may be oil or fat which has become deposited on the elements during cooking. In either event, continued use should burn away the residues. On future occasions, try to shield food with foil or keep it further away from element, particularly when grilling.

CLOCK/TIMER DOES NOT WORK

Check to be sure range cord is plugged into outlet completely. Check for a blown fuse or tripped circuit breaker. Check for power outage. Check step by step operating Instructions on previous pages.

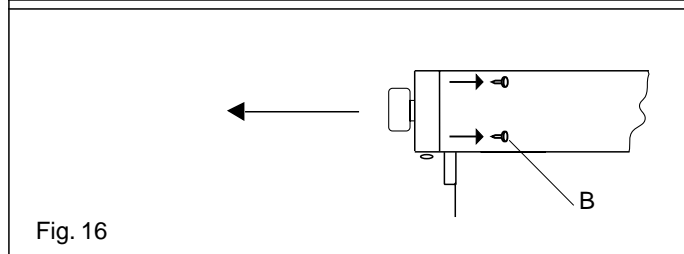
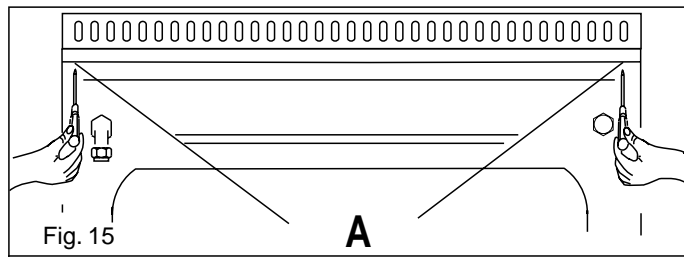

- To disassemble the control panel, unscrew the 4 internal screws (B) fixing the control panel to the oven face (fig 16).

OVEN LIGHTS

Always ensure the oven unit is switched off at the mains before replacing the oven light bulb. To remove the light bulb, unscrew the glass cover anticlockwise and remove. Turn the bulb anticlockwise and remove. Replace with the same type of bulb (Type E14 threaded clear lamp 230/240 V. 25 watt T 300 C). Replace the light carefully and turn it clockwise.

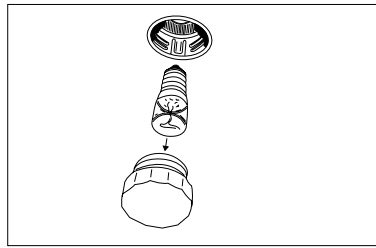

GREASING OF TAPS

If a tap becomes hard to be turned, grease it using a specific grease withstanding high temperatures. Act as follows: open the work-top and disassemble also the control panel as described on the previous paragraph. Unscrew the two fixing screws from the burner body (see picture) and remove the cone.

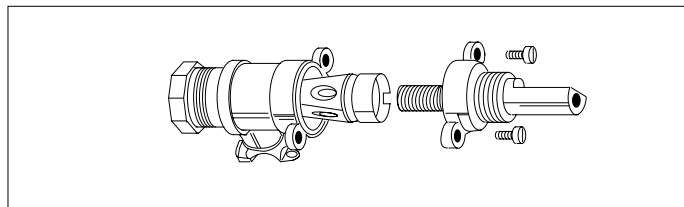

TAPS REPLACEMENT

Act as follows: open the work-top and disassemble also the control panel as described on the previous paragraph. Unscrew screw nut D of the gas tube supplying the burner. Unscrew screw V fixing the tap to the bridle and remove it (see picture).

Note: Every time the tap is replaced, it is necessary to replace the seal gasket too check the connection seal by means of soapy water.

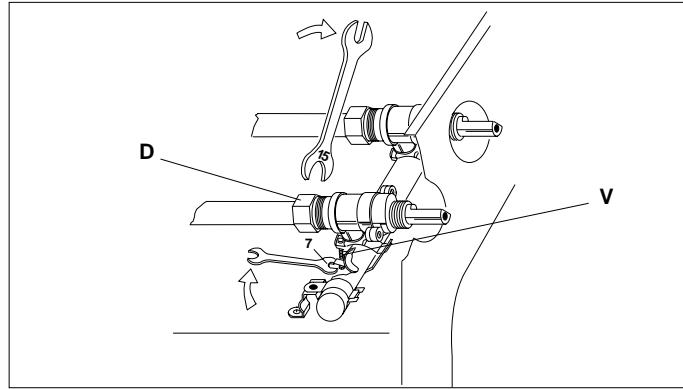

Clean the cone and its slot by means of a cloth soaked with diluent. Slightly grease the cone with the relevant grease, put it in its slot, and turn it some times. Remove the cone again, remove the exceeding grease making sure the gas entries are not obstructed by grease residuals. Assemble everything carefully in the opposite direction check the connection seal by means of soapy water.

TAPS REPLACEMENT

Act as follows: open the work-top and disassemble also the control panel as described on the previous paragraph. Unscrew screw nut D of the gas tube supplying the burner. Unscrew screw V fixing the tap to the bridle and remove it (see picture).

Note: Every time the tap is replaced, it is necessary to replace the seal gasket too check the connection seal by means of soapy water.

SOME SAFETY POINT

Do not use the appliance as a space heater.

If you smell gas

Open a window. Do not use any electrical switches. Immediately extinguish naked flames. Isolate appliance from gas mains supplies via the isolation stopcock. Contact local gas authority or emergency services as appropriate. In the event of food fire. Isolate appliance from electric / gas mains supplies if safe to do so. Try to extinguish flames with the appropriate equipment (fire blanket or extinguishing foam). Do not use water on cooking fat / oil fires.

If in difficulty call emergency services.

- Do not store or use flammable products or aerosol containers near the hotplate or burners.
- Never flambe, under an extractor - even if the ventilator is switched off. The high flames can cause fire.

For your safety and that of your children

- Do not store items that are attractive to children above or near the appliance.
- Keep children well away from the appliance: do not forget that some parts of the appliance or of the pans become very hot and dangerous during use, and will take time to cool down.
- When cooking, do not use clothes that could catch fire and cause serious injury.
- Some "Wok" cooking pots are unstable. Check with the manufacturer before purchasing.
- Avoid using unstable and misshapen pans which may tilt easily and pans with a very small base diameter, e.g. milk pans, single egg poachers. The minimum pan diameter recommended is 125mm (5"). Smaller pans will be unstable.
- Very large pans may cause walls or knobs to overheat. Using pans which are too big may deform the control knobs or discolour the walls. This is not covered by the guarantee.
- Carefully place all pans centrally over the burners.
- Always position pan handles safely away from the front of the

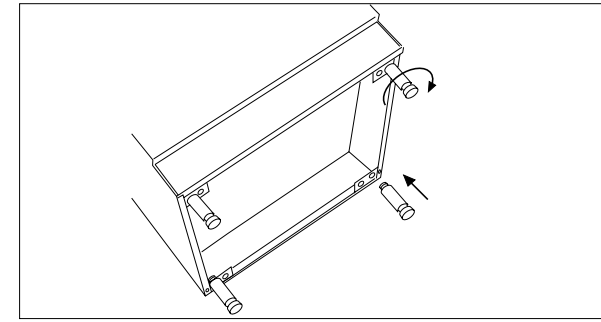

TO FIX THE COOKER TO THE REAR WALL

This is required for safety reasons.

The cooker is equipped with 2 chains fixed in the upper part of the rear right and of the rear left side (see Fig. A - position 1 and 2).

These 2 chains enable to fix the cooker to the rear wall.

To fix the cooker, act as follows:

1. By means of a drill make 2 holes with a diameter of 6mm in the wall as in Fig. B - position F (with a distance between them as per Fig. A position 1 and 2).
2. Put in these two holes part. R, then screw part. G (which are provided with the cooker) (see Fig. C).
3. Bring the cooker near the wall and put the chains on hooks G as in Fig. D - position C.

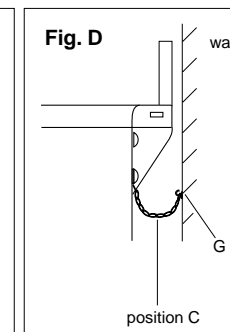
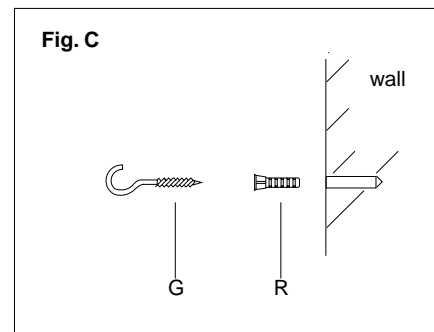
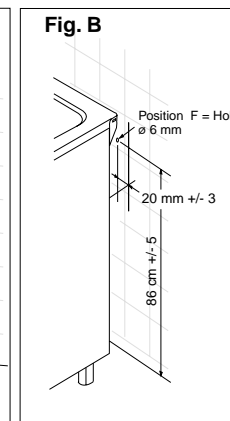
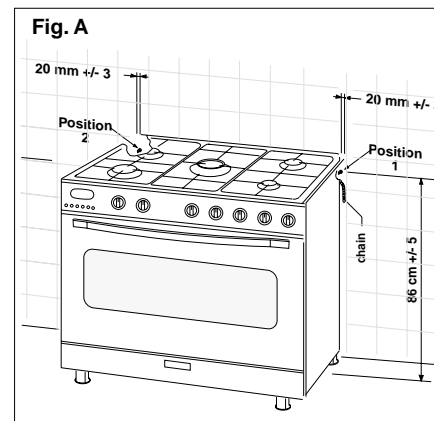

GAS CONNECTION

Should conform to gas utility regulations e.g. AS5601 Gas installations; also refer to rangehood manufacturers recommendations.

Check gas pressure, note the correct setting from the data plate sealed inside the front appliance drawer * .

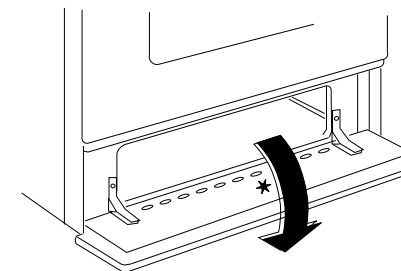

This appliance from the factory suitable for NATURAL gas bit, if necessary, can be adjusted for U-LPG by authorised person.

For the adjustments to U-LPG please operate as specified in the paragraph GAS CONVERSION AND ADJUSTMENT (pag 4).

The Gas Connection is male 1/2" BSP and is situated at the right hand rear of the appliance, approximately 40mm from the side and 695mm from the floor (depends on adjustment of feet).

The appliance shall be installed by an authorized person in accordance with the manufacturer's installation instructions, relevant local fitting regulations, municipal building regulations, the AS5601 code for gas burning appliances and equipment and other relevant statutory code band regulations. If you have some doubts, please contact the authorities for confirmation concerning the characteristics of the gas and electricity output.

The appliance is generally preset for natural gas (so no other adjustment is necessary) ensure regulator is fitted for N.G.

Ensure that all foreign matter has been cleared from the gas supply line and also purge all air from the gas system. Connect to regulator, tighten and check the installation to ensure no gas leaks occur.

IT IS RECOMMENDED THAT A SERVICETAP AND UNION BE FITTED ADJACENT TO THE APPLIANCE INLET TO FACILITATE FUTURE SERVICING.

5 burner models: set the burner pressure to 1kPa for Natural Gas and 2.75kPa for U-LPG with the wok burner operating a full rate'.

Apply a manometer to the test nipple and reset the regulator if necessary. Do not forget to replace the test nipple screw and to leave the instructions book with the user.

VERY IMPORTANT FOR THE INSTALLER

Do not attempt to turn or stress threaded elbow of the manifold: you risk damage to this part of the gas appliance which may void the manufacturers warranty.

It is not recommended that a hose assembly is used unless authorised by the local authority.

Before Leaving - Check all connections for gas leaks with soap and water. DO NOT use a naked flame for detecting leaks. Ignite all burners to ensure correct operation of gas valves, burners and ignition. Turn gas taps to low flame position and observe stability of the flame.

When satisfied with the cooker, please instruct the user on the correct method of operation.

In case the appliance fails to operate correctly after all checks have been carried out, refer to the authorised service provider in your area.

GAS CONVERSION AND ADJUSTMENT

When used with natural gas all burners have been preset at our factory and further adjustment should not be necessary. Conversion kits to other gases are available from the place of purchase. Do not attempt to fit the conversion kit yourself. Conversion to U-LPG gas should only be carried out by an authorized technician.

GAS ADJUSTEMENTS

- change the injectors
- adjust the minimum flow

*When converting from Natural Gas to U-LPG ensure that the NG regulator is removed and replaced with the Test Point Assembly. A gas regulator suitable for a supply pressure of 2.75kPa should be part of the gas tank supply and should be adjusted with the wok burner operating at maximum.

REPLACEMENT OF THE INJECTORS

When required to operate on other gas replace the injectors in accordance with information referred to in chart below.

TAB. 1 should be modified as follows:

Gas Type	kPa	Jet mm Ø	Burners	Power MJ/h
Natural gas	1.00	0.90	Auxiliary	4.0
		1.20	Semi-quick	7.1
		1.50	Quick	11.0
		1.60	Triple Crown	12.5
		1.50	Fish	11.0
U - LPG	2.75	0.53	Auxiliary	3.7
		0.73	Semi-quick	7.0
		0.95	Quick	11.7
		1.00	Triple Crown	12.9
		0.93	Fish	11.4

SPECIAL NOTE

After installation or any servicing operation, always ensure that the appliance is gas sound and that the components are now operating correctly. Items removed during servicing should be replaced in the reverse order to their removal.

In order to change the work-top injectors, it is necessary to act as follows:

- remove the grids
- remove burners and flame-spreaders.

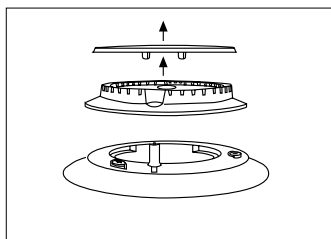

- change the injector (see Fig. C) and replace it with another one suitable for the new type of gas (see tab. 1)

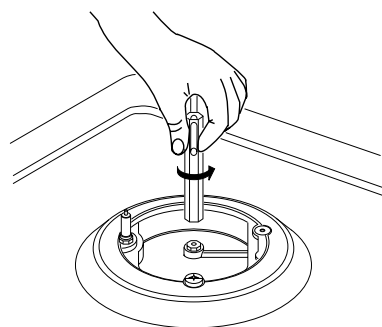

Fig. C

MINIMUM FLOW ADJUSTMENT FOR HOB-TOPTAPS

In order to adjust the minimum flame setting proceed as follows: switch the burner on, and set the knob at the minimum position. Remove the knob from the tap, place a small bladed screwdriver down the centre of the tap shaft (fig. 1).

Attention: on taps with a security valve, the minimum adjusting screw «Z» is on the body of the gas tap (fig. 2).

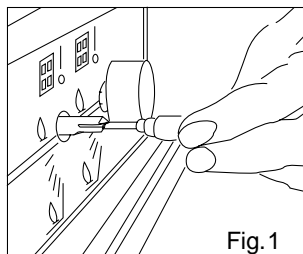

Fig. 1

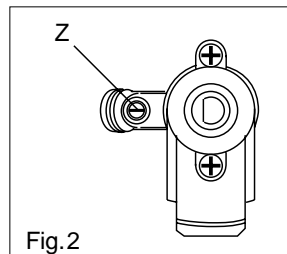

Fig. 2

Unscrew the adjusting screw in order to increase the flow or screw it to decrease the flow.

The correct adjustment is obtained when the flame has a length of about 3 or 4 mm.

For butane/propane gas, the adjusting screw must be screwed in tight.

Make sure that the flame does not go out turning quickly from the max. flow to the minimum flow.

Refit the knob again.

ELECTRICAL CONNECTION

Electric.....1.5mm² 3 core cable (15 amp fuse required)

WARNING: THIS APPLIANCE MUST BE EARTHED

Connecting the mains cable

Open the mains terminal block cover as shown, unscrew the cable clamp «A» and unscrew (not fully) the screws in the mains terminal block «L N E» which secure the three wires of the mains cable. Fit the cable and refit the cable clamp «A» (fig. N).

IMPORTANT

The wires in the mains lead are coloured in accordance with the following code:

- GREEN & YELLOWEARTH
- BLUE.....NEUTRAL
- BROWNLIVE

The supply cable must not come into contact with any component the temperature of which exceeds the ambient temperature by 50 °C.

Easy access to the plug or the switch is ensured once the appliance is installed.

Ensure that there is sufficient cable allowed for any subsequent removal of the unit.

'In order to avoid hazard, any electrical work performed on this equipment or its associated wiring, should only be done by persons authorised by the supplier or similarly qualified persons.'

2nd SECTION FOR THE USER

WARNING:

Children should be kept away while the oven or grill is in use since accessible parts become hot.



- Do not use oven base panel as a shelf, make use of the oven shelves.
- To avoid splattering and smoke, position collecting tray under the grill with some water in it.
- Always turn pan handles to the side or to the back of the hob. If they are left out into the room they can easily be hit or reached by children, this knocking the pan off the hob.
- Don't let children sit down or play with the oven door. Do not use the drop down door as a stool to reach above cabinets.
- Once your cooking is over make sure to close the main gas supply.

WARNING

* This appliance is not intended for use by young children or infirm persons without supervision.

* Young children should be supervised to ensure that they do not play with the appliance.

WARNING

Before you use the appliance for the first time, check that the plastic films protecting some parts (fascia panel, parts in stainless steel, etc.) have been removed.

- 1 Minute Tour -

Be safe

Please read the rest of the instruction book which contains important information to help you use the appliance safely and efficiently.

Daily

Regular wiping down directly after use prevents dirt from burning on. Clean the appliance with water and a detergent or all purpose cleaner.

Avoid using too much water to prevent it entering the burner or ventilation openings.

Interior: the oven shelf carriers and the back fan cover can be removed for easier cleaning. To do this, remove all the shelves and spring off the side carriers by applying pressure downwards to unhook the top. The back can now be removed by unscrewing the screw at each side. Replace in a similar manner. (Fig. Q-R)

Oven accessories (shelves, trays etc) should be washed in mild detergent solution and should not be treated with abrasives. The oven interior panels should be cleaned with mild detergent solution, mild cream cleaners or a moist soap pad.

IMPORTANT

Do not use excessive water when cleaning the oven and avoid water passing through the fan grill or ducts in the oven back. Avoid letting grease deposit collect around the upper heating element: it will cause smoking and may start a fire.

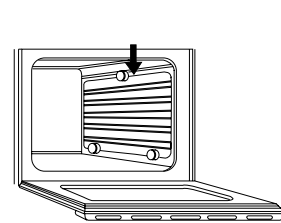

Fig. Q

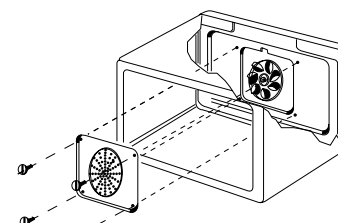

Fig. R

OVEN DOOR REMOVAL AND REFITTING

Open the door fully and turn the two hinge disks clockwise (fig.S). Reclose to about 45° and pull gently (fig.T).

To reassemble, keep the door at 45° and insert the arms of the hinge in the slots on the front of the oven, then turn the two hinge disks anticlockwise.

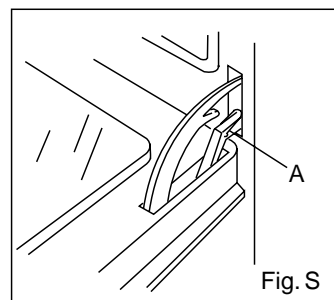

Fig. S

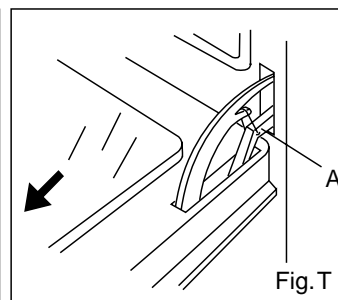

Fig. T

SERVICE INSTRUCTIONS

All service should be carried out by a authorised service technician only.

REPLACEMENT OF THE SUPPLY CABLE

ALWAYS UNPLUG THE PLUG FROM THE CURRENT SOCKET OR SWITCH OFF THE CURRENT ON THE POWER SUPPLY LINE BY MEANS OF THE MAINS CIRCUIT SWITCH, BEFORE CARRYING OUT ANY MAINTENANCE ON THE OVEN.

In case the cable is damaged, replace it in accordance with the following instructions:

- switch the appliance off at the control switch
- open the box of the supply board as described on the picture

- below; - unscrew the clamp «A» fixing the cable;
- replace the cable with one of the same length and in accordance with the specification described on the table;
- the "green-yellow" earth wire must be connected to the terminal "⊥" and it must be about 10 mm longer than the live and neutral wires;
- the «blue» neutral wire must be connected to the terminal marked with letter «N.» - the live wire must be connected to the terminal marked with letter «L».

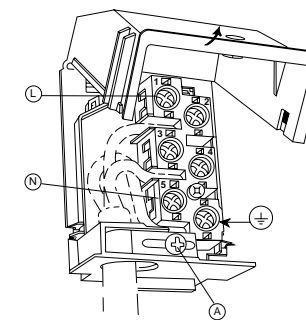

TYPE AND SECTION OF SUPPLY CABLE

230V/240V~		
H05RR-F	∅	3 x 1.5 mm ²

TYPE OF ALIMENTATION

Different connections can be made simply by moving the jumpers on the terminal board.

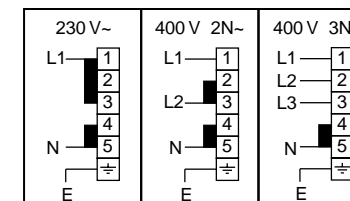

WARNINGS

Before performing any repair or operation, switch the appliance off and close the gas tap.

The manufacturer declines all responsibility for any damage to persons, animals or things caused by failure to observe the rules indicated above. In case it is necessary to repair or replace the inside components, act as follows:

WARNINGS

Isolate the cooker from the electricity supply before attempting to replace the oven lamp.

The oven lamp used is of a special type withstanding high temperatures. To replace it, act as follows: disassemble the protecting glass (A) and replace the burnt lamp with one of the same type. Reassemble the protecting glass.

DISASSEMBLE OF WORK-TOP

In case it is necessary to repair or replace the inside components, act as follows:

Remove the grids, remove burners and flame-spreaders (see fig. 13), unscrew the visible screws "V" placed on the work-top (see fig. 14). Disassemble the work-top by unscrewing the 2 rear screws "A" (see fig. 15). In this way it is possible to lift the work-top and to reach the inside components.

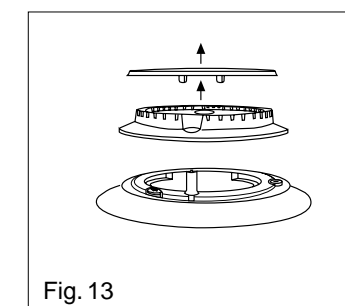

Fig. 13

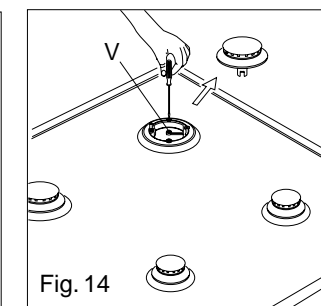

Fig. 14

Semi-automatic use with end time setting

Press the end time button. The time of day appears on the display. Set the cooking end time with + button. The AUTO and cooking time symbols light up continuously. The relay contacts switch on. When the cooking end time corresponds to the time of day, the relay and the cooking time symbol switch off. When the cooking time is up, the AUTO symbol flashes, the sound signal rings and both the relay and the cooking time button switch off.

Automatic use with cooking time and end time setting

Press the cooking time button and select the length of the cooking time with + or - button. The AUTO and cooking time symbols light up continuously. The relay switches on. By pressing the cooking end time button the next cooking end time appears on the display. Set the cooking end time with + button. The relay and the cooking time symbol switch off.

The symbol lights up again when the time of day corresponds to the cooking start time. When the cooking time is up, the AUTO symbol flashes, the sound signal rings, the cooking time symbol and the relay switch off.

Minutes counter

Press the minutes counter button and set the cooking time with + or - button. The bell symbol lights up when the minutes counter is operating. When the set time is up, the sound signal rings and the bell symbol switches off.

Sound signal

The sound signal starts at the end of a programme or of the minutes counter function and it lasts for 15 minutes. To stop it, push any one of the functions buttons.

Start programme and check

The programme starts 4 seconds after it has been set. The programme can be checked at any time by pressing the corresponding button.

Setting error

A setting error is made if the time of day on the clock falls within the cooking start and end times. To correct the setting error, change the cooking time or cooking end time. The relays switch off when a setting error is made.

Cancelling a setting

To cancel a setting, press the cooking time button and then press the - button until 00 00 appears on the display. A set programme will automatically cancel on completion.

USE OF THE ELECTRIC GRILL

USING THE GRILL

Turn the oven knob to the right and place it on the grill position .

The grill pan should be located on the top oven shelf position and is provided with a detachable grill pan handle which is engaged centrally over the front edge of the pan between the indentations provided. A wire grid is supplied. The grill pan handle should be removed from the grill pan during the grilling operation and only fitted for removal or insertion of the grill pan particularly when hot. Always preheat the grill on full for 3-5 minutes before inserting the food.

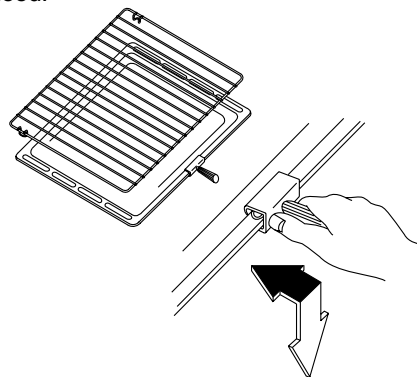

CLEANING

Before cleaning the appliance, close the gas stopcock and unplug appliance or disconnect power at the main circuit breaker of the electrical system.

Do not clean the appliance surfaces when still hot.

Always clean off spillage as quickly as possible to prevent burning on which will make removal more difficult. Wash with a clean cloth soaked in hot soapy water, rinse and dry with a soft cloth.

DO NOT USE ABRASIVES. CAUSTIC PASTES OR SPRAYS. COARSE CLEANING PADS OR POWDERS. DO NOT USE EXCESSIVE WATER WHEN CLEANING YOUR OVEN IN ORDER TO AVOID WATER PRESSING THROUGH CLEFTS INTO THE BACK OF CONTROLS PANEL OR OF THE UNIT.

Pan supports and burners

The burner heads can be removed for cleaning.

NB Do not drop hot burner caps in cold water.

Because of the rapid cooling they might get damaged.

Lift off and soak for about 10 minutes in hot water with a little detergent. After having cleaned and washed them, dry them carefully.

Make sure that no burner holes are clogged.

Clean the burners once a week or more frequently if necessary.

Make sure you have reassembled the burners correctly.

Pan supports can be washed by hand or in a dishwasher.

Remember to remove rubber feet (if fitted) prior to washing.

Refit them afterwards.

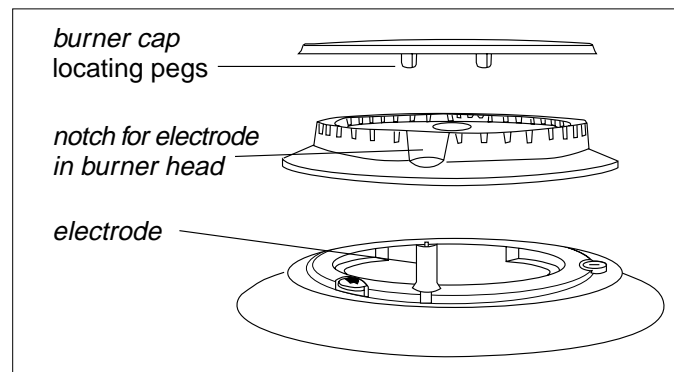

For a triple crown burner, make sure head "C" and covers "A" and "B" are properly placed on their seats as figure N and not off-centered as in figure P.

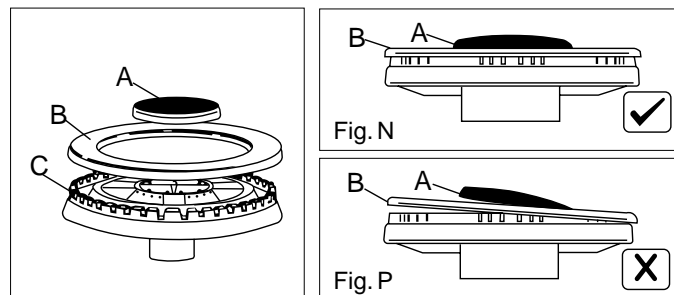

Gas and Electricity on

Make sure that the gas supply is turned on and that the appliance is plugged in and switched on. The ignitor needs electricity. In case there is no electric current, the burner can also be lighted using a match.

It is recommended that pans suitable to the size of the burner should be used as follows:

BURNERS	PANS	
	fl min.	fl max
AUXILIARY	80 mm	160 mm
SEMI-RAPID	120 mm	200 mm
RAPIDE	180 mm	230 mm
TRIPLE CROWN	230 mm	260 mm

Always use pans with a flat base diameter, which are well balanced and stable in use, a pan which overhangs the hotplate should not be used. Avoid using old, misshapen pans, or pans which are unstable when placed on a flat surface. Do not use "split pans" as they are inherently unstable.

To save gas, always position pans centrally over the burners and adjust the flames so that they do not lick up the sides of the pan and only the base is heated. Always put lids on saucepans and boil only the amount of liquid you use. When the liquid has boiled adjust the setting to maintain a simmer. Do not light the burner until the pan is in position and turn off the burner before removing the pan. In hard water areas, descale kettles regularly. For safety, keep saucepan handles turned to a safe position so they are out of reach of small children and cannot be accidentally knocked.

To turn the burner OFF, turn the control knob clockwise to the OFF setting (marked with a dot ●)

Automatic electric ignition

To turn on a burner, press the knob corresponding to the selected burner and turn it anticlockwise to the maximum position. Keeping the knob pressed, the electric automatic ignition of the burner will be started up. In case there is not electric current, the burner can also be lighted using a match.

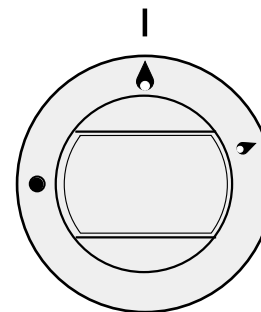

The small flame indicates the 'low position'. Turn the knob to it after the contents of a pan have boiled.

The smaller burners are for smaller pans and simmering. Make sure flames are under the pans. Using a lid will help the contents boil more quickly.

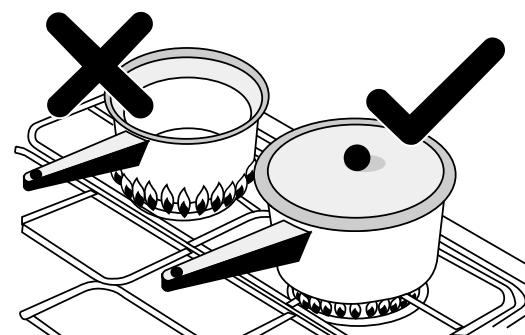

WARNING

It is not recommended to press push button for ignition if all the burners are not located in the proper positions. The burner heads, burner skirts and pan supports are removable for better cleaning. Always ensure that the burner skirts and heads are replaced correctly so that the burners function safely and correctly. During the use of the appliance pay attention that water or any liquid does not enter into the appliance through the holes of the burners or around the rods of the valves or the push button electronic lighter.

Water or juice will produce dangerous short-circuits and can seriously damage the working of the Hotplate.

HOW TO USE YOUR ELECTRIC OVEN

- Before cooking in the first time we recommend that the oven should be operated at 200 °C for 30 minutes to remove any manufacturing greases and odours.

- Do not place items or pan directly on to the oven bottom.

- Foil should only be used to cover food and not oven shelves or party of the oven. When used improperly will obstruct the air circulation causing problems in cooking and/or harmful accidents.

- MULTIFUNCTIONAL OVEN

The oven is fitted with:

- a lower heating element;
- an upper heating element;
- a circular heating element surrounding the fan.

N.B.: Always set the temperature on the thermostat knob before selecting any of the functions.

Oven thermostat knob

To obtain an oven temperature between 60 °C and MAX °C, turn knob clockwise.

Oven commutator knob

Depending on the type of oven, it is possible to select one of the following functions turning the commutator knob clockwise.

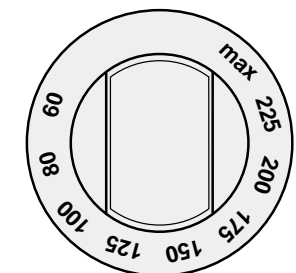

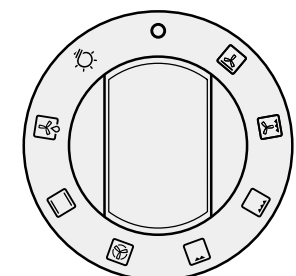

Note:

All the functions mentioned above switch the oven internal light on. A warning light on the control panel will stay lit until the temperature is reached; after it will light up intermittently. Always use the oven with the oven door closed.





Use of the oven

Note: ovens with separate thermostat and commutator.

When the functions   are used, place the thermostat knob between 180 °C and 200 °C as maximum temperature.

ATTENTION:

The temperature shown on the control panel corresponds to the temperature in the oven centre only when the functions selected are  or .



When you turn the control knob to this position, the light will be on for all the following operations.



Defrosting with fan

The air at ambient temperature is distributed inside the oven for defrosting food very quickly and without proteins adulterations. The thermostat knob must be placed on the maximum position.



Natural convection

Both the lower and upper heating elements operate together. This is the traditional cooking, very good for roasting joints, ideal for biscuits, baked apples and crisping food. You obtain very good results when cooking on a shelf adjusting the temperature between 60 and MAX °C.



Fan oven

Both the fan and the circular heating element operate together. The hot air adjustable between 60 and MAX °C is evenly distributed inside the oven. This is ideal for cooking several types of food (meat, fish) at the same time without affecting taste and smell. It is indicated for delicate pastries.



Medium grill

It is indicated for grilling and gratinating small quantities of traditional food. The thermostat knob must be placed on the maximum position.



Total grill

It is indicated for grilling and gratinating traditional food. Turn the thermostat control knob to the 200 °C position.



Fan assisted total grill

The air which is heated by the grill heating element is circulated by the fan which distributes the heat on the food. The fan assisted grill replaces perfectly the turnspit. You can obtain very good results also with large quantities of poultry, sausage, red meat. Turn the thermostat control knob to the 200 °C position.



Air forced lower heating element

The air which is heated by the lower heating element is circulated by the fan which distributes the heat on the food. This function can be used to sterilize food. This function can be used between 60 and MAX °C.

GENERAL INSTRUCTION

Warning: remember ovens get hot; some parts naturally become very hot, notably the glass oven door and the protective strip. Keep children away from oven at all times and warn them about the danger.

GUIDE FOR CONVENTIONAL COOKING

(Outer ring of upper electric element and lower electric element ON) The following Cooking Guides give the recommended shelf positions (counted from the bottom), thermostat settings and approximate cooking times for a range of baked items, using the

conventional oven, using one tray only. Cooking results are a matter of personal preference and may easily be adjusted to suit individual requirements by slight adjustment of the temperature and/or cooking time. Preheating of the oven is recommended for 10-15 minutes or until the oven thermostat indicator light switches off to show the selected temperature has been reached.

When using a baking tray it should be placed centrally on the oven shelf with the short sides of the tray parallel to the sides of the oven. Do not use trays, tins or dishes larger than 380 mm (15") long, 356 mm (14") wide, as cooking results may be impaired.

Food	Thermostat setting ; C	Shelf Position (Counted from Bottom)	Cooking Time
Small cakes (12 on tray)	195	3	20 - 30 mins.
Victoria sandwich 190 (2x7"/180mm)		3	25 - 35 mins.
Swiss roll or whisked sponge	200	3	20 - 25 mins.
Fruit cake (8"/205mm)	155	2	2 - 3 hours.
Scones	260	3	10 - 20 mins.
Meringues	95	2	2 - 3 hours.
Shortcrust Pastry	210	3	25 - 45 mins. depending
Puff or Flaky Pastry	220	2	20 - 35 mins. upon
Choux Pastry	220	3	25 - 35 mins. dish
Biscuits	200/220	3	15 - 25 mins. depending upon type
Bread	250	2	30 - 40 mins.
Milk pudding	165	2	1 H - 2 hours.
Pizza	270	3	25 mins.
Lasagne	170	3	75 mins.
Oven noodles	160	3	75 mins.
BEEF on bone & crusty (rare)	270 rare	3	12 mins. per 1/b (500 g) plus 12 mins.
(medium)	220 ;C	3	15 mins. per 1/b (500 g) plus 15 mins.
(well done)	220 ;C	3	20 mins. per 1/b (500 g) plus 20 mins.
LAMB on bone	180 ;C	3	25 mins. per 1/b (500 g) plus 15 mins.
	220 ;C	3	20 mins. per 1/b (500 g) plus 20 mins.
	170 ;C	3	27 mins. per 1/b (500 g) plus 27 mins.
Boned and rolled	220 ;C	3	25 mins. per 1/b (500 g) plus 25 mins.
	170 ;C	3	35 mins. per 1/b (500 g) plus 20 mins.
PORK on bone	220 ;C	3	25 mins. per 1/b (500 g) plus 25 mins.
Boned and roller	180 ;C	3	30-35 mins. per 1/b (500 g) plus 35 mins.
VEAL on bone	220 ;C	3	25 mins. per 1/b (500 g) plus 25 mins.
Boned and roller	220 ;C	3	30 mins. per 1/b (500 g) plus 30 mins.
CHICKEN	220 ;C	3	20 mins. per 1/b (500 g) plus 20 mins.
	170 ;C	3	25 mins. per 1/b (500 g) plus 25 mins.
TURKEY	220 ;C	3	20 mins. per 1/b (500 g)
	170 ;C	3	25 mins. per 1/b (500 g)
DUCK	220 ;C	3	20 mins. per 1/b (500 g)
	170 ;C	3	25 mins. per 1/b (500 g)
GOOSE	220 ;C	3	20 mins. per 1/b (500 g) plus 20

PLATE WARMING

Ovenproof plates and dishes may be warmed in the oven on a low temperature setting. Remember do not place items directly into the oven base.

Warning: do not use foil to cover the oven shelves, or any part of the oven interior including the oven base. Foil should only be used to cover food and cooking dishes. Always place items which may boil over (e.g. fruit pies) on a baking tray to prevent spillage burning onto the oven base. Foil used improperly is frequent cause of oven problems and painful accidents. Avoid letting grease deposit collect around the upper heating element: it will cause

smoking and may start a fire.

Remember do not place pan or items directly onto the oven base. Never leave unit unattended at high heat settings. Boil over causes smoking and greasy spill over that may start a fire.

If a grease fire should occur in a pan put out the flame by placing a lid on the pan. Do not throw water on a grease fire.

GUIDE FOR FORCED CONVECTION COOKING

(Back rolled electric element with fan)

The accessories provided with the oven can be slotted in at 5 positions: the following guide concerns cooking times and thermostat settings using N. 2 shelves on the same time (in position N. 2 and N. 4). Cooked results are a matter of personal preference and may easily be adjusted to suit individual requirements by slight adjustment of the temperature and/or cooking time, or when using more or less shelves in the same time. Preheating of the oven is recommended for 10-15 minutes or until the oven thermostat indicator light switches off to show the selected temperature has been reached.

When using a baking tray it should be placed centrally on the oven shelf with the short sides of the tray parallel to the sides of the oven. Do not use trays, tins or dishes larger than 380mm (15") long, 356 mm (14") wide, as cooking results may be impaired.

Food	Thermostat setting ; C	Cooking Time
Small cakes (12 on tray)	175	15-25 mins.
Victoria sandwich (2x7"/180mm)	170	20-30 mins.
Swiss roll or whisked sponge	180	15-20 mins.
Fruit cake (8"/205mm)	135	1 H - 2 H hours.
Scones	210	8-15 mins.
Meringues	80	1 H - 2 H hours.
Shortcrust Pastry	190	20-40 mins. depending
Puff or Flaky Pastry	200	15-30 mins. upon
Choux Pastry	200	20-30 mins. dish
Biscuits	170/180	10-20 mins. depending upon type
Bread	200/220	25-35 mins.
Milk pudding	150	1 H - 2 hours.
Pizza	250	20 mins.
Lasagne	165	60 mins.
Oven noodles	150	60 mins.
BEEF on bone & crusty	230 rare & crusty	9 mins. per 1/b (500 g) plus 9 mins.
BEEF on bone	190 ;C (rare)	15 mins. per 1/b (500 g) plus 8 mins.
	190 ;C (medium)	20 mins. per 1/b (500 g) plus 10 mins.
	160 ;C (well done)	25 mins. per 1/b (500 g) plus 8 mins.
Boned and rolled	190 ;C (rare)	20 mins. per 1/b (500 g) plus 10 mins.
	190 ;C (medium)	25 mins. per 1/b (500 g) plus 15 mins.
	160 ;C (well done)	30 mins. per 1/b (500 g) plus 8 mins.
LAMB on bone	190 ;C	20 mins. per 1/b (500 g) plus 10 mins.
	155 ;C	27 mins. per 1/b (500 g) plus 14 mins.
Boned and rolled	190 ;C	25 mins. per 1/b (500 g) plus 14 mins.
	155 ;C	25 mins. per 1/b (500 g) plus 14 mins.
PORK on bone	200 ;C	25 mins. per 1/b (500 g) plus 14 mins.
Boned and roller	160 ;C	30-35 mins. per 1/b (500 g) plus 18 mins.
VEAL on bone	200 ;C	25 mins. per 1/b (500 g) plus 14 mins.
Boned and roller	200 ;C	30 mins. per 1/b (500 g) plus 14 mins.
CHICKEN	200 ;C	20 mins. per 1/b (500 g) plus 10 mins.
	155 ;C	25 mins. per 1/b (500 g) plus 13 mins.
TURKEY	200 ;C	18 mins. per 1/b (500 g) plus 14 mins.
	155 ;C	23 mins. per 1/b (500 g)
DUCK	200 ;C	18 mins. per 1/b (500 g)
	155 ;C	23 mins. per 1/b (500 g)
GOOSE	180 ;C	18 mins. per 1/b (500 g) plus 20 mins.

USING THE GRILL

The grill is situated in the top of the oven compartment. The grill pan should be located on the top oven shelf position.

Warning:

Do not place fatty foods too close to the grill and never leave the grill unattended. If fatty foods are grilled, or roasting has been cooked in the oven at a high temperature the grill element may smoke. This is not dangerous and the smoke is caused by the fat burning off when the grill element is hot. Leave the grill element on until the smoking has stopped then use as normal. If a grease fire should occur in a pan put out the flame by placing a lid on the pan. Do not throw water on a grease fire.

INSTRUCTIONS FOR USE OF CONTROL DEVICES

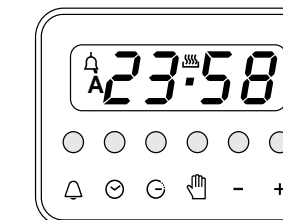

	Minute timer
	Cooking time
	Cooking end
	Manual
-	Subtract time
+	Add time

Programmer with electronic clock - LED display

Functions

Cooking time, cooking end time, manual position, clock, minutes counter, times to be set up to 23 hours 59 minutes.

Display

Fluorescent display with 4 figures of 7 segments to indicate time and cooking times.

Cooking time and manual function = pan symbol

Automatic function = AUTO

Minutes counter = bell symbol

The symbols light up when the corresponding functions are selected.

Setting

To set, press and release the desired function, and within 5 seconds set the time with + and - buttons.

+ and - buttons.

The + and - buttons increase or decrease the time at a speed depending on how long the button is pressed.

Setting the time

Press any two buttons (cooking time, end time, minutes counter) at the same time, and + or - button to set the desired time. This deletes any previously set programme. The contacts are switched off and the AUTO symbol flashes.

Manual use

By pressing the manual button the relay contacts switch on, the AUTO symbol switches off and the saucepan symbol lights up. Manual operation can only be enabled after the automatic programme is over or it has been cancelled.

Automatic use

Press the cooking time or end time button to switch automatically from the manual to the automatic function.

Semi-automatic use with cooking time setting

Press the cooking time button and set the desired time with + or -. The AUTO and cooking time symbols light up continuously. The relay switches on immediately. When the cooking end time corresponds to the time of day, the relay and cooking time symbol switch off, the sound signal rings and the AUTO symbol flashes.